Windjammer SS/IV/V, Windstar Mounting Instructions

Yamaha

1981-82 XJ550 Maxim

warning

THE HARDWARE DESCRIBED IN THIS MANUAL WAS DESIGNED TO MOUNT THIS VETTER FAIRING TO THE MOTORCYCLE(S) DESIGNATED.

If you are unable to determine if this hardware is for your motorcycle, contact your dealer. If your dealer is unavailable, contact the Vetter Corporation, Customer Service Department, Rantoul, IL, 61866, (217) 893-9300. These instructions contain valuable information for future reference. They must be given to the customer.

note:

This manual may cover several motorcycles and some illustration details may differ from your model. Please follow the instructions.

Prepare for Fairing Installation

1. Put the motorcycle on its center stand.
2. Remove the seat by opening the storage compartment at the back of the seat and unhooking the two rubber straps. Lift and pull the seat towards the rear of the bike.
3. Remove the 8mm bolt at the back of the gas tank. Turn the petcocks to "on" position and remove the gas and vacuum lines. Pull tank up and towards the rear. Remove and set aside to prevent damage.
4. Remove the two phillips head screws in the headlight rim, disconnect and remove the headlight.



5. Remove the two 8mm bolts holding the nacelle to the headlight stays and the 6mm adjuster screw located under the nacelle. Remove the nacelle.

note: It will be necessary to disconnect some wiring to remove the nacelle. Reconnect the wires upon removal of the nacelle.

6. Disconnect the tachometer and speedometer cables at the instruments and let hang for now.
7. Disconnect clutch cable from engine. Pull towards front of bike around frame and exhaust tubes. Let hang.
8. Remove the Yamaha name plate located on the front of the triple clamp. (Illus. 1)
9. Remove the two 6mm nuts holding the instruments. These will be reused. Remove the one bolt holding the headlight stays/turnsignal assemblies to the lower triple clamp. Lift the assembly up and forward and remove it.
10. Replace the instruments and replace the two 6mm nuts and washers.
11. Disconnect the horn wires and remove the horn from the frame and set aside for now.

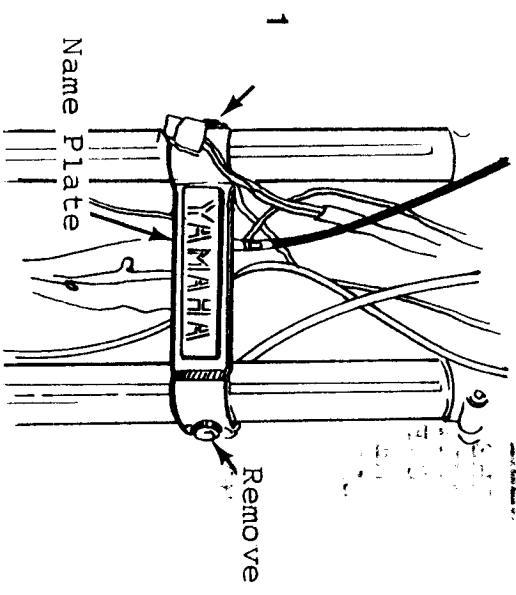

Electrical Connections

1. Route the Vetter wiring harness between the frame and the left fork tube. Attach the 3-prong plug in the harness to the motorcycle's headlight socket.

2. Connect the remaining wires following the color code below:

Fairing Wire	Function	Bike Wire
White.....	High Beam.....	Yellow
Yellow.....	Low Beam.....	Green
Black.....	Ground.....	Black
Violet.....	Left Turnsignal.....	Brown
Blue.....	Right Turnsignal.....	Dark Green
Green.....	Running Lights.....	Light Blue
Red.....	Lighter (Option).....	Light Brown
Brown.....	Windjammer (horn opt).....	Battery Wire (+)
	Windstar 12V Unswitched	
Orange.....	Windjammer (horn opt).....	Pink
	Windstar 12V Switched.....	Light Brown

caution

THE ORANGE, BROWN AND RED FAIRING WIRES ARE CONNECTED AS ABOVE ONLY FOR THE ACCESSORIES LISTED. ANY WIRING NOT USED SHOULD BE COVERED AT THE END WITH ELECTRICAL TAPE. IF YOU DECIDE TO USE THESE WIRES FOR OTHER ACCESSORIES, MAKE SURE YOUR MOTORCYCLE'S ELECTRICAL SYSTEM WILL TOLERATE THE EXTRA CURRENT DEMAND.

DUE TO THE LIMITED CHARGING ABILITIES OF THE 550CC AND SMALLER MOTORCYCLES, IT MAY BE NECESSARY TO DISCONNECT THE RUNNING LIGHTS IF THE BATTERY DOESN'T MAINTAIN A CHARGE. THIS COMPANY DOES NOT RECOMMEND THE OPTIONAL QUARTZ HEADLIGHT ON SMALL MOTORCYCLES FOR THE SAME REASON.

Plug the male bullets into the appropriate female connectors. Gently pull all connectors to make sure they are tight. If not, crimp the outside of the connectors with wire crimpers or pliers after the connection is made.

For wires without connectors, use the provided blue connectors as shown. (Illus. 2)

- Snap the blue connector over the appropriate motorcycle wire.
- Insert the appropriate fairing wire into the other hole. The wire will not go all the way through the connector.
- Squeeze the metal tab down flush with the top of the connector.
- Fold the plastic lid down and snap it shut.

3. Compress all the wiring into a tidy bundle and insert it into the black vinyl bag. Cinch up the drawstring and tie the excess around the bag and the hydraulic brake line. Sit the bag upside-down to keep water out.



2

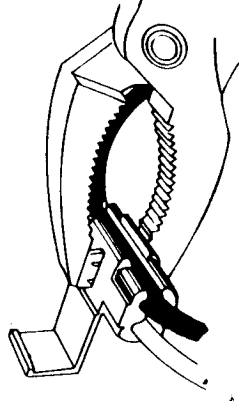

Install Mounting Bracket

note: For detailed information on the use of engine guards with this hardware, consult page 5 of the Owner's Manual.

warning

DUE TO THE DESIGN OF THIS PARTICULAR BRACKET, IT SHOULD NOT BE CUT OR ALTERED IN ANY MANNER TO ACCEPT ANY TYPE OF ENGINE GUARD.

1. Remove the two side reflectors and their shrouds located on the frame downtubes by removing the four phillips head screws.
2. Position the bracket on the frame as shown. (Illus. 3)
3. Fit the lower saddle pads with four hose clamps as shown. (Illus. 3) Leave the clamps slightly loose.
4. Fit the backing plate behind the frame as shown. (Illus. 3) Do not pinch any wires with the backing plate when installing.
5. Install the 8x35mm bolt, two flat washers and lock nut, through the bracket and backing plate. (Illus.3) Do not tighten at this time.
6. Check bracket for horizontal alignment by viewing it from directly in front of the motorcycle. If adjustment is required, tap the bracket to a level position. (Illus. 4)
7. Tighten all hose clamps and the mounting bolt securely. Make sure no wires are between the bracket or backing plate where damage could occur to the wires.
8. Reconnect the tachometer and speedometer cables at the instruments.

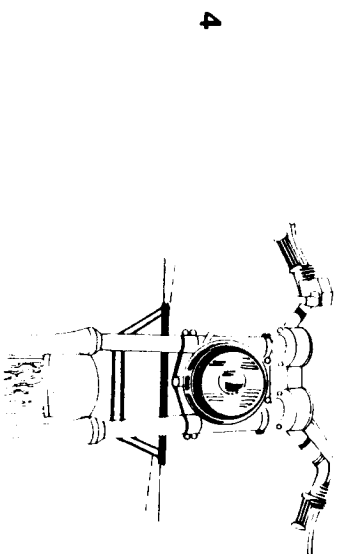
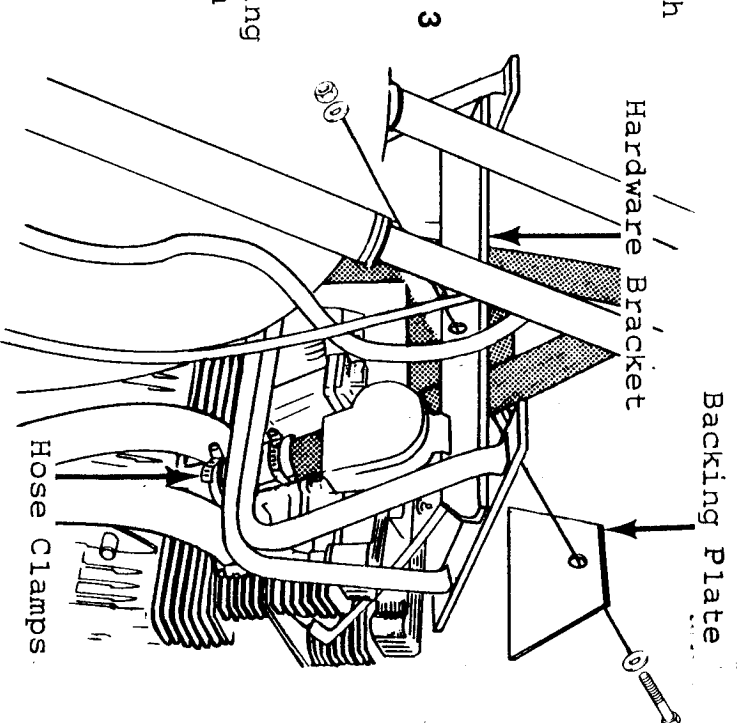

9. Route the clutch cable on the outside of the lower crosstubes and reconnect. (Illus. 5)
10. Remount the horn in the stock position and reconnect the wires.

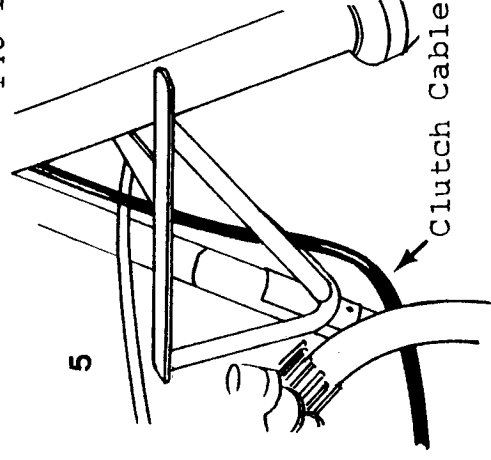

warning

FOR YOUR OWN PROTECTION, USE ALL PROVIDED MOUNTING CLAMPS AND CHECK THEM PERIODICALLY FOR TIGHTNESS.

Mount the Fairing

WJ SS/IV only:

If you are planning to install Vetter color inserts, they should be applied before the fairing is mounted.

note:

If you are installing the optional horn kit, refer to the instructions packaged with the kit.

1. Set the fairing on the mounting bracket. Install four mounting bolts through the holes and install washers and locknuts on the bolts. (Illus. 6)

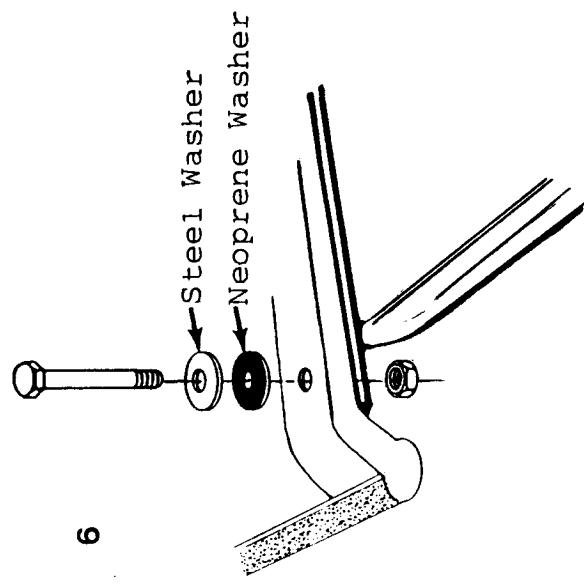

2. Before tightening the nuts, plug the external wire harness into the fairing at the serial number plate. Check all electrical components before continuing. Refer to the Troubleshooting section of your Owner's Manual if problems arise.
3. Now tighten the four bolts enough to slightly compress the neoprene washers.

4. Fit the provided reflectors to the mounting clamps with the 6mm nuts provided.
5. Install each assembly on the fork slider as shown. (Illus. 7)

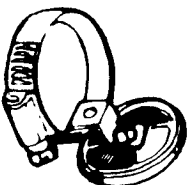

7

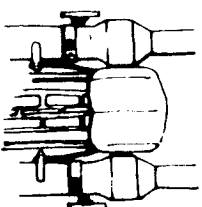

Refer to your Owner's Manual for windshield mounting instructions and final adjustments. We suggest you insert these instructions in the manual for future reference.

warning

AFTER INSTALLATION, THE FAIRING OR BRACKET MUST NOT INTERFERE WITH ANY PART OF YOUR MOTORCYCLE. CHECK THE AREA BETWEEN YOUR MOTORCYCLE FORKS AND THE FAIRING FOR CONTACT AT ANY POINT (CABLES, HORNS, ETC.), WHILE TURNING THE HANDLEBARS COMPLETELY FROM SIDE TO SIDE.

USE THIS SCALE TO CHECK BOLT AND WASHER DIMENSIONS

