

140 130 058
© Vetter Corporation 1979
Rev. 9-23-79

NOTE: Federal legislation requires that this manual be given to the consumer. It contains the customer's copy of the Limited Warranty and includes future reference material.

Floating Mount Tail Trunk

Owner's Manual and Mounting Instructions



Vetter

Floating Mount Tail Trunk

Owner's Manual and Mounting Instructions

Table of Contents

Introduction	2
Hardware Description	3
Wiring Instructions	4
Installing Hardware	4
Mounting Tail Trunk	5
Replacement Parts	6
Optional Accessories	6
Troubleshooting & Maintenance	7
Customer Service	7
Warranty	7

Introduction

This manual contains important information regarding the proper installation, safe use, and maintenance of your Tail Trunk. We urge you to read it completely and follow the recommendations to obtain the most trouble-free and enjoyable use.

Statements preceded by the following words are of special significance. Heed them well!

WARNING — Means there is the possibility of injury to yourself and others.

CAUTION — Means there is the possibility of damage to the equipment.

Use the illustrated hardware description while unpacking your Tail Trunk. You will immediately recognize the various parts and will easily understand the assembly steps that follow. Working straight through the manual will assure that you forget nothing during installation.

WARNING — Improper Tail Trunk installation and loading can cause an accident.

Adding to the load your motorcycle will carry requires that you give special attention to several important details: loading procedures, weight of the load, tire and suspension maintenance, and riding technique.

Never overload your motorcycle. Observe the weight limitations posted on the Tail Trunk and Saddle Bags, and your motorcycle's total weight as shown on the tire information label or

in your owner's manual. Load the heavier items in the forward part of the Saddle Bags, balance the weight between the right and left bags. Carry only lighter items in the Tail Trunk again with heavier items to the front.

Be certain to maintain the tire pressures listed in your owner's manual, and check tires often for wear. Consult your owner's manual for suspension settings. If the rear suspension does not perform adequately under additional weight and spring adjustment doesn't help, you may want to fit stronger shock absorbers. See your dealer for recommendations.

Finally, adapt your riding style to minimize the effects of the added weight on your motorcycle chassis. Avoid sudden, full throttle operation when starting from a standstill or while negotiating turns. Carefully coordinate the application of the front and rear brakes. And allow yourself enough orientation time before heading out on traffic or on a long ride.

All information herein is based on the latest product information available at the time of publication. The Vetter Corporation reserves the right to change design and specifications and/or make additions to or improvements to products without imposing on itself any obligation to make such changes in products previously manufactured.

Hardware Description

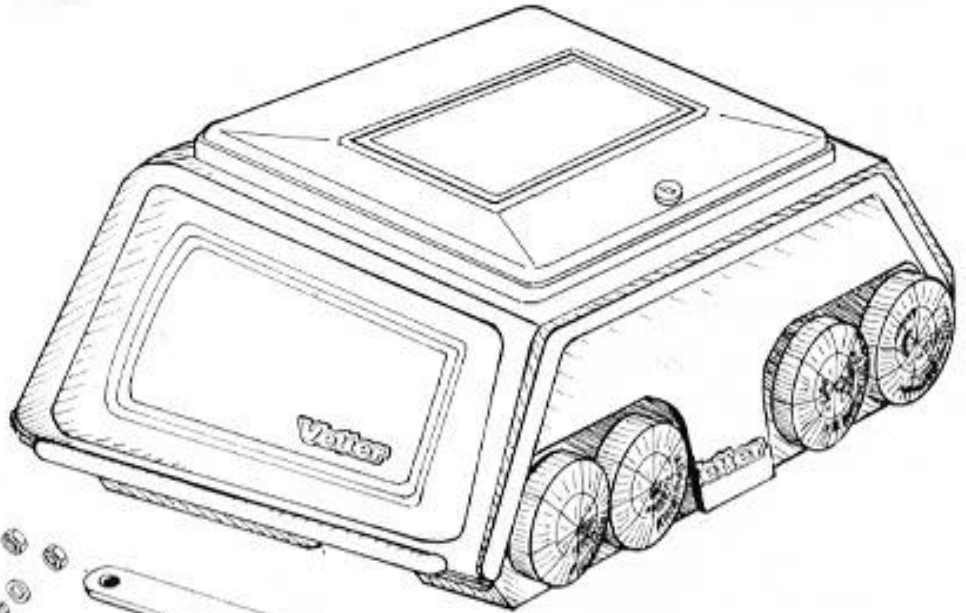

U-Bolts

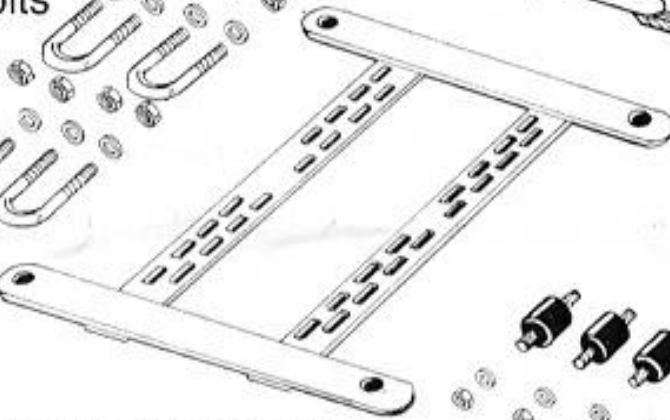
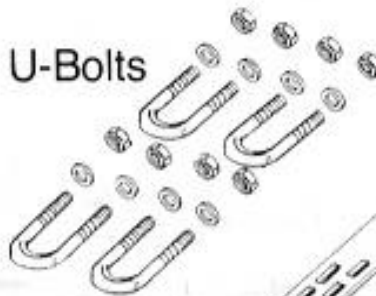

Mounting Bracket



Rubber Isolators

Mounting Hardware

Channel Adapter Kit
(Option)

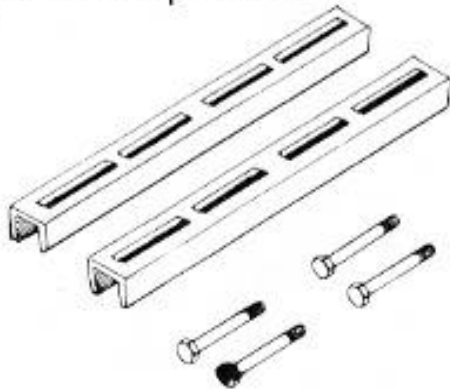

External Wiring Harness

Running Lights

The tail light wiring colors shown are typical for the brands listed. If the colors do not conform with the wiring on your motorcycle, consult your owner's manual, shop manual, or your dealer.

NOTE: The Tail Trunk wires are extra long to accommodate a variety of motorcycles. You may choose to cut them shorter, or simply loop the excess wire and secure it with a ty-rap.

Place the Tail Trunk on the luggage rack to determine how much wire is needed and how you want to route the wiring, then remove the trunk.

Attach the Tail Trunk wiring harness using the blue connectors supplied. Snap a connector over the motorcycle's tail light wire as shown. Insert the GREEN Tail Trunk running light wire into the blocked hole.

Squeeze the metal tab down flush with the top of the connector. Fold the plastic lid down and snap it shut. Repeat the procedure for the Tail Trunk ground (BLACK) wire.

Secure the wiring harness to the frame with a ty-rap, and route the wiring between the frame and left rear of the seat. Place the Tail Trunk on the luggage rack and connect the wiring harness. Turn on the motorcycle's headlight to test the Tail Trunk's running lights. If problems arise, refer to "Troubleshooting" section on Page 7. Disconnect plug and remove Tail Trunk.

Vetter & Standard Luggage Racks

Follow this procedure for Vetter and other round-tube luggage racks:

Remove the four lock nuts from the isolator studs on the BOTTOM of the mounting bracket, and detach the bracket from the trunk. Center the mounting bracket on the luggage rack with the narrow end to the rear. Fit the four U-bolts from below the luggage rack tubes through the appropriate slots in the bracket cross bars. Secure the U-bolts with the eight flat washers and lock nuts supplied, but do not tighten completely.

The bolts should be loose enough to permit fore and aft movement of the bracket.

Wiring Instructions

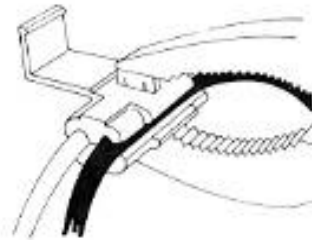
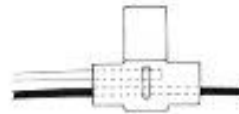

Brand	Tail Light	Ground Wire
BMW	Gray/black	Brown
Harley-Davidson	Green	Black
Honda	Brown	Green
Kawasaki	Red	Black/yellow
Moto Guzzi	Yellow	Black
Norton	Brown/Green	Red
Suzuki	Brown	Black/white
Triumph	Brown/green	Red
Yamaha	Blue	Black

Install Hardware

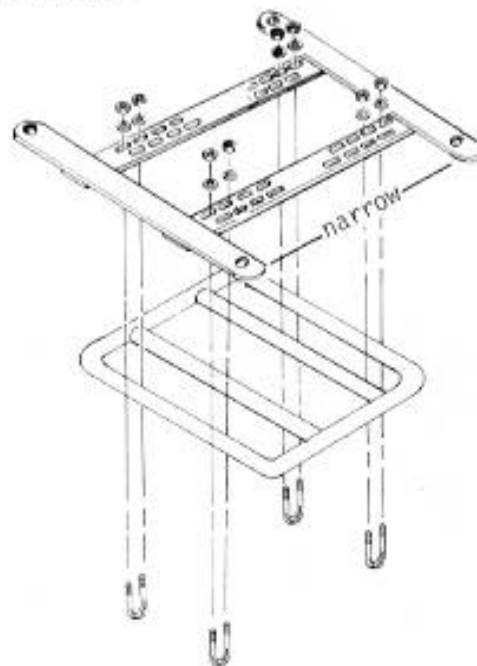

Optional Adapter

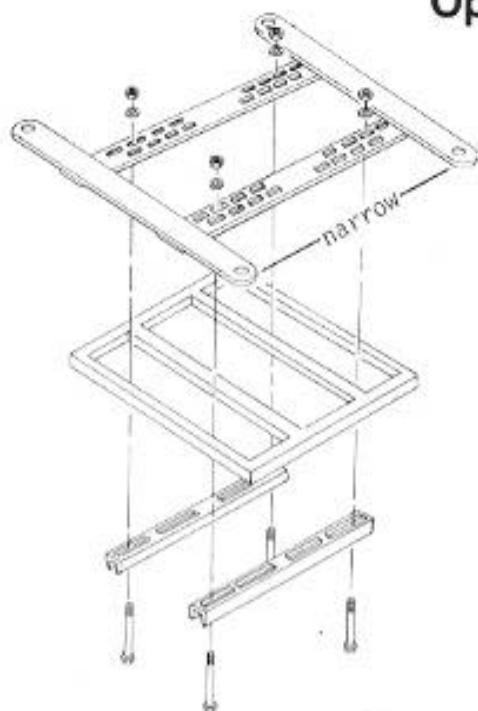

Square-Tube Luggage Racks

Remove the four lock nuts from the rubber isolator studs on the **BOTTOM** of the mounting bracket, and detach the bracket from the trunk. Center the mounting bracket on the luggage rack with the narrow end to the rear. Fit each adapter channel, flat side up, and insert the four 6 x 40mm bolts through the corresponding slots in the mounting bracket. Install the flat washers and lock nuts originally supplied for the U-bolts, but do not tighten completely. The bolts should be loose enough to permit fore and aft movement of the bracket.

Mount Tail Trunk

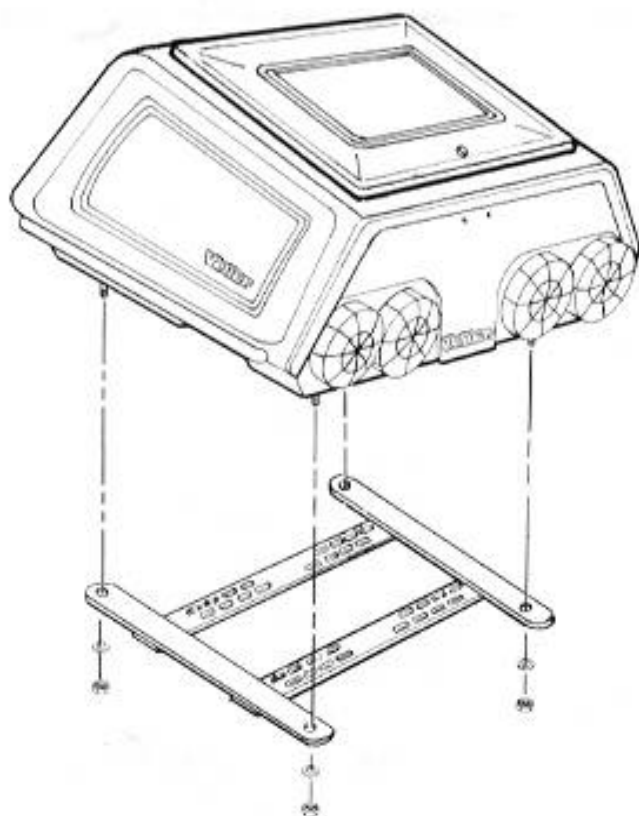

Trunk Position

Install the Tail Trunk on the mounting bracket, but do not add the washers or lock nuts. Check the position of the back rest in relation to the passenger and seat, and adjust the trunk accordingly by sliding the mounting bracket forward or back. For the best weight distribution in terms of motorcycle handling, the Tail Trunk should be located as far forward as possible.

When you have it positioned, remove the Tail Trunk and tighten the U-bolts securely.

CAUTION — Work in a diagonal pattern to avoid twisting the mounting bracket. Do not overtighten the U-bolt nuts. Damage to the luggage rack may result.

NOTE: On some motorcycles, the luggage rack or Tail Trunk will interfere with the operation of the hinged seat. In this case, we suggest you remove any tools, manuals, or items normally kept under the seat and store them in the Saddle Bags, Tail Trunk or fairing.

Again install the Tail Trunk and fit each stud with a flat washer and lock nut. Tighten each nut to 7 ft-lb. torque.

Insert the wiring harness plug into the socket in the Tail Trunk. Be sure the connection is tight. Secure the wiring harness to the luggage rack with a ty-rap.

Replacement Kits

(All kits include mounting hardware.)

1. Lid and Color Panel Kit
*(Also available in Lid Only and Panels Only form)
2. Texas Trim Kit
*(Also available for rear or sides only.)
3. Gold Striping Set
4. Back Rest Kit
5. Lock Assembly
Consult your Vetter dealer to purchase or order replacement parts.

Optional Color Inserts

Color inserts available in Gold, Red, Blue and Orange for the lid and color panels. See your dealer to purchase or order replacement parts.

COLOR PANEL INSTALLATION

When installing color panels, fit the retainers and push them flush against the body. To change or replace color panels, use small snap ring pliers or small screwdriver to loosen the locking tabs on the retainers.

Replacement Parts & Options

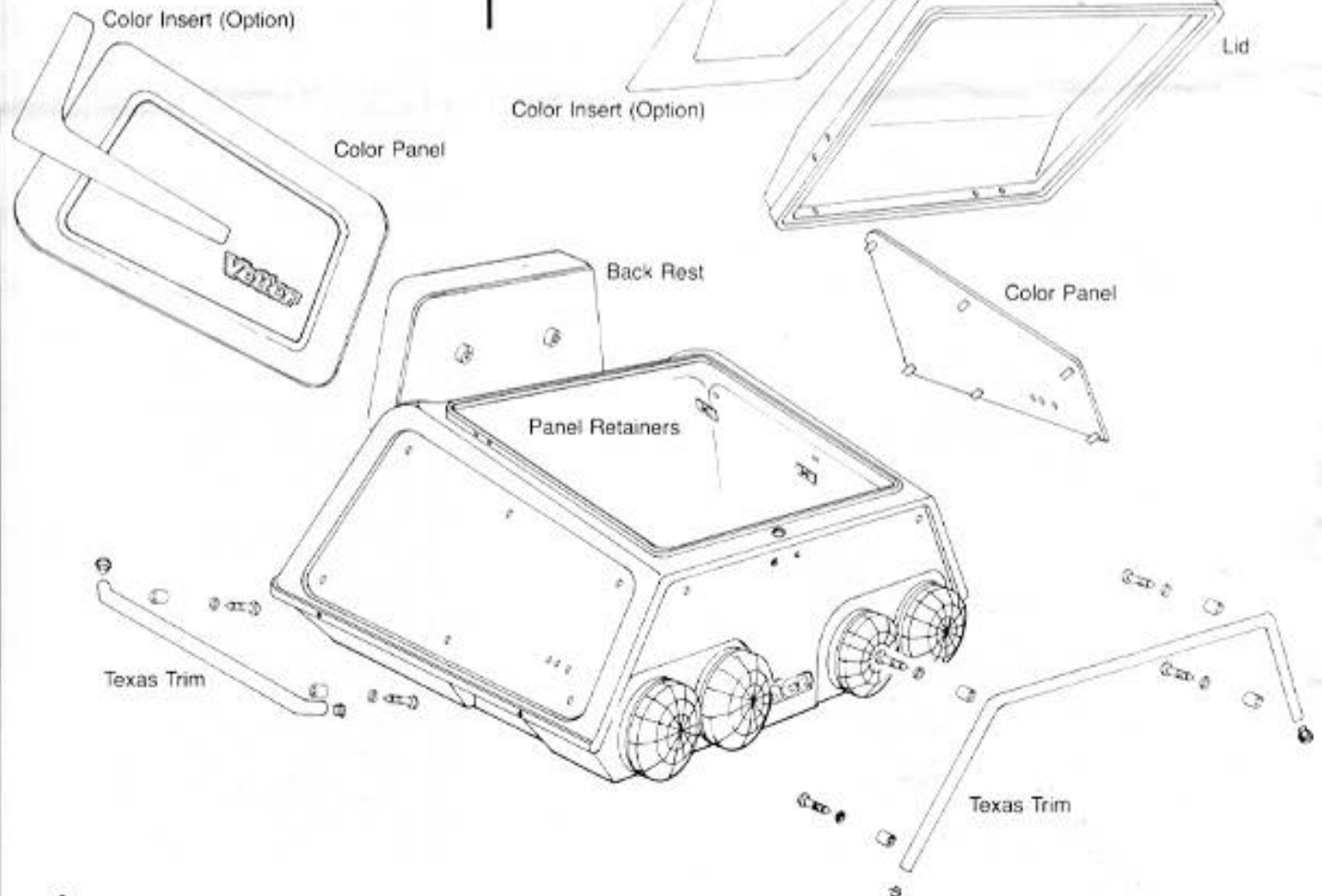
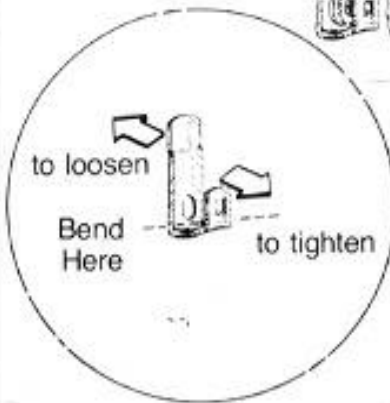
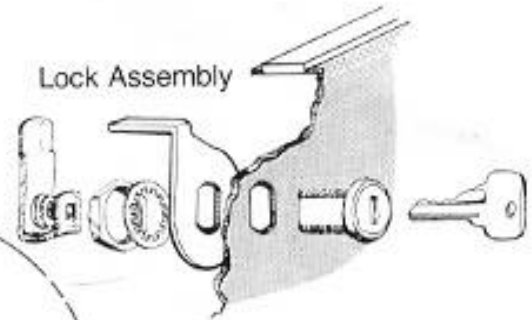

Troubleshooting & Maintenance

Electrical Problems

First check your bike's color code to be sure the proper wires are connected. Check all connections for tightness.

If your battery won't maintain a charge, check the bike's charging system to ensure that it is working properly. Also check the battery's electrolyte level and be sure the battery is in good condition.

If the electrical system checks out, you may have to keep your engine RPM up by using lower gears when riding in town. You may also consider changing to lower wattage bulbs in the Tail Trunk and other accessories. If problems persist, you may choose to just disconnect the Tail Trunk when driving in town and/or disconnect the center two driving lights.

Mounting

The best answer to almost any problem is to reread your instructions carefully. Sometimes it is helpful for someone else to look the problem over, especially someone who has not been working on the installation with you, such as your dealer.

Maintenance

The Floating Mount Tail Trunk requires little maintenance, but we recommend that you make periodic checks. The mounting bolts and mounting clamps should be checked for tightness and adjustments made as necessary.

Cleaning and waxing the Tail Trunk. When washing your trunk, use a mild detergent and warm water. Washing should be done with a soft cloth or sponge. Avoid spraying water under pressure directly at the joint between the lid and the body of the trunk as some water may enter the trunk itself. Waxing the trunk is easy; furniture polish works as well as anything we have found. Spray the polish on a rag rather than on the trunk itself, however, as if it is sprayed on the bag the wax becomes very difficult to remove from the bag's textured surface.

CAUTION: Do not use cleansers which contain methyl or ethyl alcohol.

CAUTION: Hydraulic fluid will damage your trunk. Never allow it to come in contact with your trunk.

With normal use the body of your tail trunk may become scratched or marred. Small cosmetic touch-ups can be accomplished by treating the area with a hot air gun (a hair dryer is not hot enough) or a propane torch. Using either the torch or the hot air gun, pass back and forth over the marred area in a sweeping motion at a safe distance from the trunk surface. The correct amount will smooth and restore shine to the damaged area. If the area in concern is located near the lid or a painted part, that part should be removed before any treatment is performed.

Painting Instructions

If you wish to repaint your lid or color panels, we recommend that the following instructions be used:

1. Remove the logo and stripe decals.
2. Sand thoroughly with 320 grit wet sandpaper.
3. Resand with 400 grit wet sandpaper.
4. Dry thoroughly.
5. Spray with Dupont 100S Multi-Purpose Primer.
6. Spray Dupont Weight Lifter Acrylic Enamel with 792S or 793S Hardener.
7. Install new vinyl decals.

Tail Trunk Striping

When removing striping, the suggested method is to use 3M Woodgrain and Striping Remover, part number 08907, followed by 3M Adhesive Remover, part number 08908. Please follow the directions on the spray cans. These products can be obtained from your Vetter dealer or at most paint and automotive stores that carry 3M products.

When handling striping, do not crease or bend it. Always handle striping from the edges, never from the ends. Do not pull the backing paper off the striping with expectations of reapplying. Backing paper will not restick.

If you have any questions on storing, handling, removing or applying of striping, please contact your dealer. If your dealer is unavailable, contact your Customer Service Department.

Replacement Parts

We recommend that you always use Genuine Vetter Replacement Parts. Contact your local Vetter dealer to purchase or order replacement parts.

Customer Service

Any problems concerning installation of the Tail Trunk should be referred to your dealer. If your dealer is unavailable, contact the Customer Service Department, Vetter Corporation, Rantoul, IL 61866. We are here to serve you: (217) 893-9300. In order to provide the maximum amount of service to you and the dealer, it is necessary that you fill out the Owner's Registration Card and promptly return it to Vetter Corporation. We also suggest you record your Tail Trunk serial number here:

so you'll have it should you ever need to contact us: (It is located on the wiring socket plate.)

Also record your key number here:

so that you can order replacement locks if necessary.

Limited Warranty — Vetter Corporation

This warranty applies to products manufactured or distributed by Vetter Corporation, Rantoul, IL 61866, and sold by Vetter Corporation or its authorized dealers within the United States, Puerto Rico, and the Virgin Islands. It is given to the first retail purchaser only and is not transferable to subsequent owners.

Warranty Obligation: Vetter Corporation warrants that it, or one of its authorized dealers, will repair or, at its option, replace any part proven to be defective in factory material or workmanship within six (6) months (unlimited mileage) of the date of purchase. Parts repaired or replaced under this warranty are warranted only during the balance of the original warranty period. THIS WARRANTY DOES NOT INCLUDE ANY LABOR CHARGES FOR TROUBLESHOOTING, REMOVAL OR INSTALLATION.

Exclusions from Coverage: 1. Any repairs or replacements or parts necessitated by misuse, negligence, fire accident, damage caused by exposure to gasoline, brake fluid, harmful solvents and cleaners, paints, or repair material, use of unauthorized accessories, faulty installation, installation upon motorcycles or vehicles not listed in Vetter Corporation's retail and dealer catalog sheets, or improper or unreasonable maintenance are not covered. 2. This warranty does not cover "Totes" rainboots. **DISCLAIMER OF CONSEQUENTIAL DAMAGES AND LIMITATIONS OF IMPLIED WARRANTIES: TO THE EXTENT THE LAW PERMITS, VETTER CORPORATION SHALL NOT BE LIABLE UNDER ANY CIRCUMSTANCES FOR LOSS OF USE OF THE PRODUCT, CONSEQUENTIAL OR INCIDENTAL DAMAGES, ANY IMPLIED WARRANTY ARISING UNDER LAW, INCLUDING THOSE OF MERCHANTABILITY AND FITNESS FOR A PARTICULAR PURPOSE, IS LIMITED TO THE DURATION OF THIS LIMITED WARRANTY.**

IMPORTANT: Some states do not allow limitations on how long an implied warranty lasts and/or limitations or exclusions of consequential or incidental damages, so the above limitations may not apply to you.

To Obtain Warranty Service: Information you must provide when filing claim: 1. Name, mailing address and telephone number. 2. Selling dealer's name and address. 3. Serial number on serialized products. 4. Model and year of motorcycle. 5. Date product was purchased. 6. Date and mileage at failure. 7. Description of problem.

Steps to take: 1. Contact or take your product to an authorized Vetter dealer (preferably your selling dealer) at your expense. 2. If you are unable to obtain warranty service, or should your warranty claim be denied for reasons that you consider unjustifiable, contact your dealership owner. Normally, this should resolve your problem. However, if you require further assistance, write or call the Customer Service Department of Vetter Corporation, Rantoul, IL 61866 (217) 893-9300. At this point, you must be prepared to return the part in question to Vetter Corporation with all freight charges prepaid. The charges will be reimbursed to you if they total over \$5.00 (five dollars) and the warranty claim is honored. This warranty gives you specific legal rights and you may also have other rights which vary from state to state.

Vetter Corporation
September 30, 1978

WARNING

**READ CAREFULLY
BEFORE LOADING**

**DO NOT EXCEED
MAXIMUM LOAD**

EACH SADDLE BAG

TAIL TRUNK*

LUGGAGE RACK
W/O TAIL TRUNK

TOTAL

20LB (9KG)

20LB (9KG)

20LB (9KG)

60LB (27KG)

 THE SADDLEBAGS, TAIL TRUNK, AND LUGGAGE RACK ARE FOR LIGHT WEIGHT ITEMS. EXCESSIVE WEIGHT AND IMPROPER LOADING MAY AFFECT MOTORCYCLE STABILITY, DECREASE SAFE OPERATING SPEED, AND CAUSE MOUNTING HARDWARE OR LUGGAGE FAILURE.

 FACTORS BEYOND OUR CONTROL SUCH AS OPERATOR'S WEIGHT, PASSENGER'S WEIGHT, WEIGHT OF OTHER ACCESSORIES, ETC. MAY FURTHER REDUCE THE SAFE AMOUNT OF WEIGHT CARRIED IN OUR SADDLEBAGS AND TAIL TRUNK OR ON THE LUGGAGE RACK.

 DISTRIBUTE THE LOAD EQUALLY ON BOTH SIDES OF THE MOTORCYCLE TO MINIMIZE IMBALANCE.

 DO NOT EXCEED YOUR MOTORCYCLE'S VEHICLE CAPACITY LOAD LIMIT AS SHOWN ON ITS TIRE INFORMATION LABEL AND IN YOUR MOTORCYCLE OWNER'S MANUAL.

 REFER TO THE INSTALLATION INSTRUCTIONS FOR ADDITIONAL INFORMATION. IF YOU HAVE ANY QUESTIONS CONTACT YOUR DEALER. IF HE IS NOT AVAILABLE, CONTACT:

CUSTOMER SERVICE DEPT.
VETTER CORPORATION
RANTOUL, IL 61866
(217) 893-9300