Windjammer SS/IV/V Mounting Instructions Suzuki

1977 GS750EB, 1978 GS750EC, 1000EC, 1979 GS750EN, LN, 850GN, 1000EN
1980 GS850GT, GLT, 1000ET, GT, GLT, 1981 GS850GX, GLX, 1000GX, GLX

warning

THE HARDWARE DESCRIBED IN THIS MANUAL WAS DESIGNED TO MOUNT THIS VETTER FAIRING TO THE MOTORCYCLE(S) DESIGNATED.

If you are unable to determine if this hardware is for your motorcycle, contact your dealer. If your dealer is unavailable, contact the Vetter Corporation Customer Service Department, Rantoul, IL 61866 (217)893-9300. These instructions contain valuable information for future reference. They must be given to the customer.

note: This manual may cover several motorcycles and some illustration details may differ from your model. Please follow the written instructions.

Prepare for Fairing Installation

1. Put the motorcycle on its center stand.

note: To avoid scratching during installation, we suggest that you either remove or cover the gas tank.

2. Remove the screws from the headlight rim.
3. Disconnect and remove the headlight. Remove the bolts holding the headlight shell in place and remove the shell.
4. Disconnect and remove the turnsignals from the headlight stays.

caution

THE FORKS/SIDE REFLECTOR MOUNT MUST BE REMOVED TO PROVIDE ADEQUATE CLEARANCE BETWEEN THE FORKS AND FAIRING HARDWARE. USE THE FOLLOWING STEPS TO REMOVE THE MOUNT.

5. Disconnect the tachometer and speedometer cables.
6. Remove the large chrome cap nut from the triple clamp. On some models it will be necessary to unscrew the tension adjuster on the choke control, then unscrew the plastic nut. Reach below the steering head and pull the choke cable as far forward as possible. Pull the slack up through the steering head. (Illus. 2)

7. Loosen the three pinch bolts on the triple clamp. (Illus. 1)

8. Lift the triple clamp and handlebar assembly up and off being careful not to damage any cables or instruments.

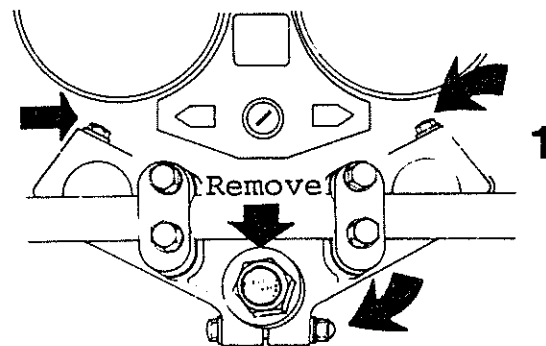

9. Carefully rotate the handlebars and triple clamp to one side. Remove the headlight stay on the exposed side. Repeat for other side.

10. Tilt the handlebar assembly back and remove the reflector bracket.

11. Reinstall the top triple clamp.

12. Replace the chrome cap nut and tighten the nut and pinch bolts to factory torque specifications. If you removed your choke assembly, replace it at this time and tighten securely.

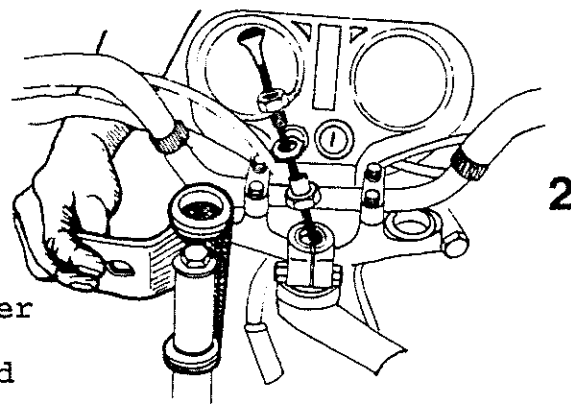

13. Reroute and reconnect the speedometer in front of the lower triple clamp. All models except 750,850,1000GT and 1000GX's reconnect the tachometer cable at this time.

1977 750 Only:

YOU MUST RELOCATE THE HORN AND THE INSTRUMENT ASSEMBLY TO PROVIDE ADEQUATE FAIRING CLEARANCE.

- A. Move the instruments to the top of the fork triple clamp mounting bosses as shown. (Illus. 3) Reinstall bolts, washers and nuts.
- B. Disconnect the tachometer cable from the engine.
- C. Remove the horn from the motorcycle frame. the horn will be relocated.
- D. Remove the side reflectors from the forks. The reflectors will be reused.

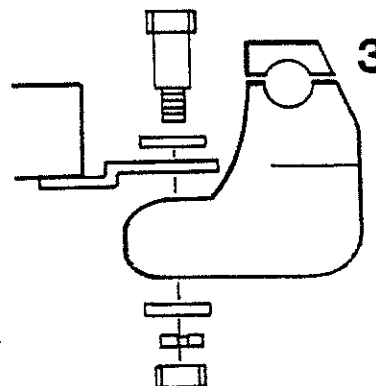

Electrical Connections

1. Route the Vetter wiring harness between the frame and left fork tube. Attach the 3-prong plug in the harness to the motorcycle's headlight socket.
2. Connect the remaining wires following the color code:

Fairing Wire	Function	Bike Wire
White.....	High Beam.....	Yellow
Yellow.....	Low Beam.....	White
Black.....	Ground.....	Black/White
Violet.....	Left Turnsignal.....	Black
Blue.....	Right Turnsignal.....	Green
Green.....	Running Lights.....	Brown
Red.....	Cigarette Lighter (option)...	Orange
Brown.....	Accessory (horn option).....	Battery Wire (+)
Orange.....	Accessory (horn option).....	Green

3. Gently pull all bullet connections to make sure they are tight. If not, crimp the outside of the connectors with wire crimpers or pliers after the connection is made.

caution

THE ORANGE, BROWN AND RED FAIRING WIRES ARE CONNECTED AS ABOVE ONLY FOR THE ACCESSORIES LISTED. ANY WIRING NOT USED SHOULD BE COVERED AT THE END WITH ELECTRICAL TAPE. IF YOU DECIDE TO USE THESE WIRES FOR OTHER ACCESSORIES, MAKE SURE YOUR MOTORCYCLE'S ELECTRICAL SYSTEM WILL TOLERATE THE EXTRA CURRENT DEMAND.

4. For the remaining connections, use the provided blue connectors as shown. (Illus. 4)

- Snap the blue connector over the appropriate motorcycle wire.
- Insert the appropriate fairing wire into the other hole. The wire will not go all the way through the connector.
- Squeeze the metal tab down flush with the top of the connector.
- Fold the plastic lid down and snap it shut.

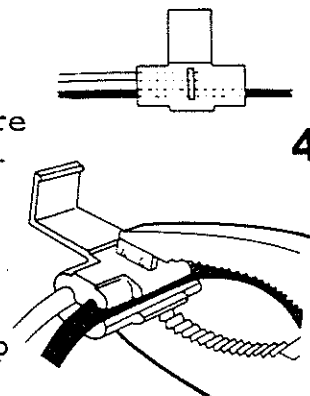

5. Cover all the wiring connectors with the black vinyl bag supplied. Cinch up the drawstring and place the bag upside-down to keep water out. Hook two ty-raps end to end and secure the bag to the wire harness going into the instrument panel.

Install Mounting Bracket

note: For detailed information on the use of engine guards with this hardware, consult page 5 of the Owner's Manual.

1. Slip the saddle pads on the U-bolts. Install the mounting bracket on the frame using the U-bolts, flat washers and locknuts on the upper cross bar. Use the provided hose clamps on the lower mounting pads. (Illus. 5)

1977 750 Only:

- A. Reinstall the horn on the left U-bolt as shown. Rotate the horn counter-clockwise until the horn bracket contacts the opposite side of the U-bolt. Reinstall the tachometer cable to the engine.

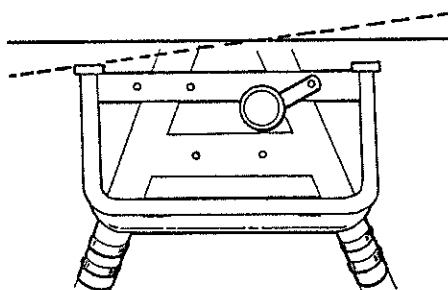

2. View the bracket from directly in front of the motorcycle. If the bracket is not level, tap it into position as required.
3. Making sure the U-bolts are at right angles to the bracket, tighten the locknuts and hose clamps securely.

750,850,1000GT,GX Only:

- A. Be sure the choke cable and the wiring harness are above the bracket and the tachometer cable is routed through the bracket. Reconnect the tachometer cable at the instruments.

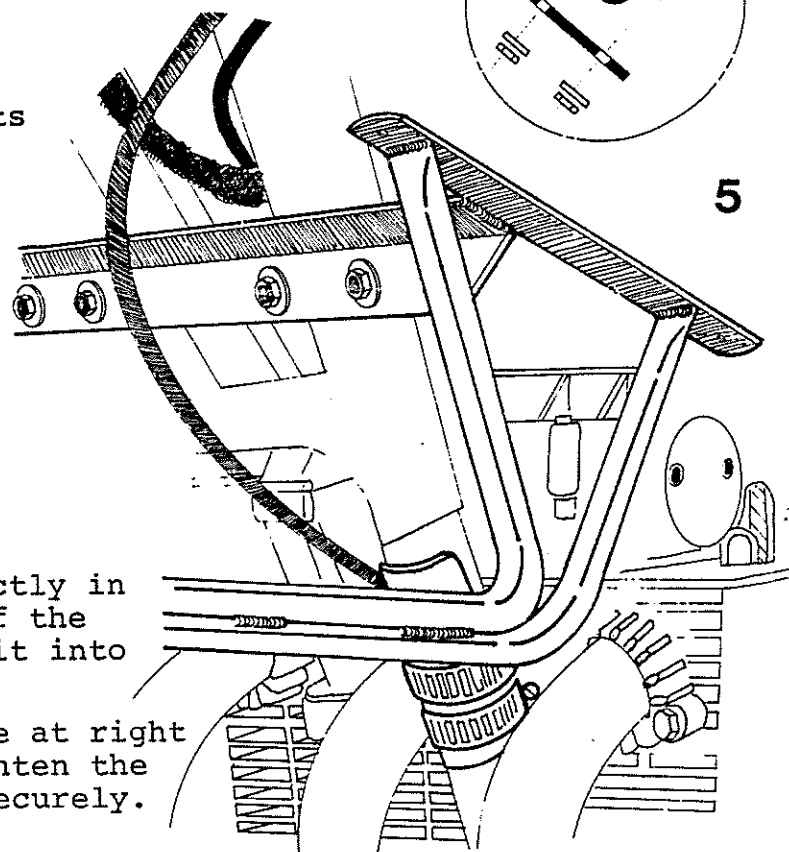
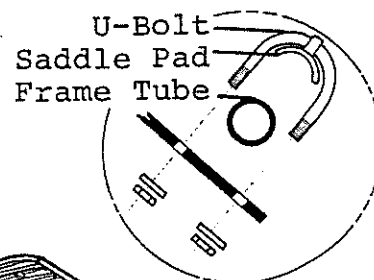

warning

FOR YOUR OWN PROTECTION, USE ALL THE PROVIDED MOUNTING CLAMPS AND CHECK THEM PERIODICALLY FOR TIGHTNESS.

Mount the Fairing

WJ SS/IV Only: If you are planning to install optional Vetter color inserts, they should be applied before the fairing is mounted.

note: If you are installing the optional horn kit refer to the instructions packaged with the kit.

1. Prepare the four 6x35mm bolts with the steel and neoprene washers as shown. (Illus. 6)
2. Set the fairing on the mounting bracket and secure it with the prepared bolts and four locknuts.
3. Before tightening the nuts, plug the external wire harness into the fairing at the serial number plate. Check all electrical components before continuing. Refer to the Troubleshooting section of your Owner's Manual if problems arise.
4. Tighten the four nuts enough to slightly compress the neoprene washers.
5. Fit the supplied reflectors to each hose clamp with the provided 6mm locknuts. Install each assembly on the fork sliders as shown (Illus. 7)

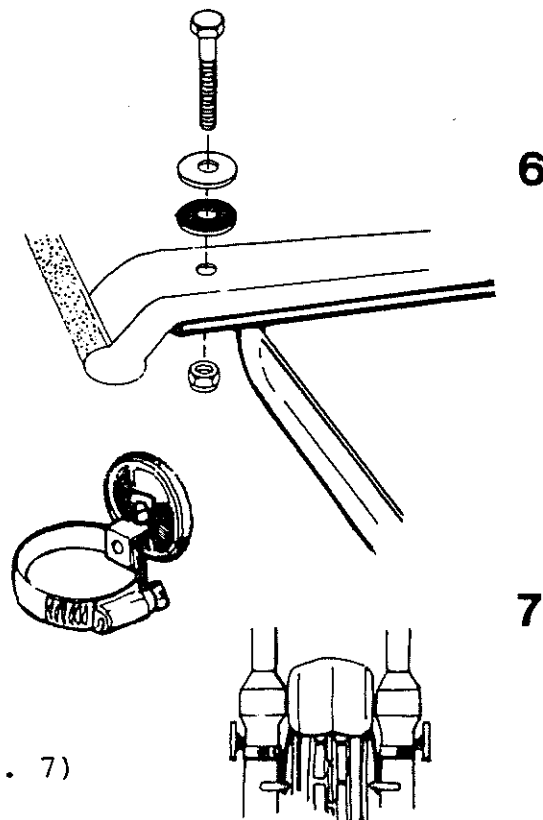

warning

AFTER INSTALLATION, THE FAIRING OR BRACKET MUST NOT INTERFERE WITH ANY PART OF YOUR MOTORCYCLE, CHECK THE AREA BETWEEN YOUR MOTORCYCLE FORKS AND THE FAIRING FOR CONTACT AT ANY POINT (CABLES, HORNS, ETC.), WHILE TURNING THE HANDLEBARS COMPLETELY FROM SIDE TO SIDE.

Refer to your Owner's Manual for windshield mounting instructions and final adjustments. We suggest you insert these instructions in the Owner's Manual for future reference.

USE THIS SCALE TO CHECK BOLT AND WASHER DIMENSIONS

