

EG 3167
© Vetter Corp. 1978
1-18-78
Rev. 10-5-78

Floating Mount Saddle Bags

Owner's Manual
and Mounting Instructions

Honda 750F

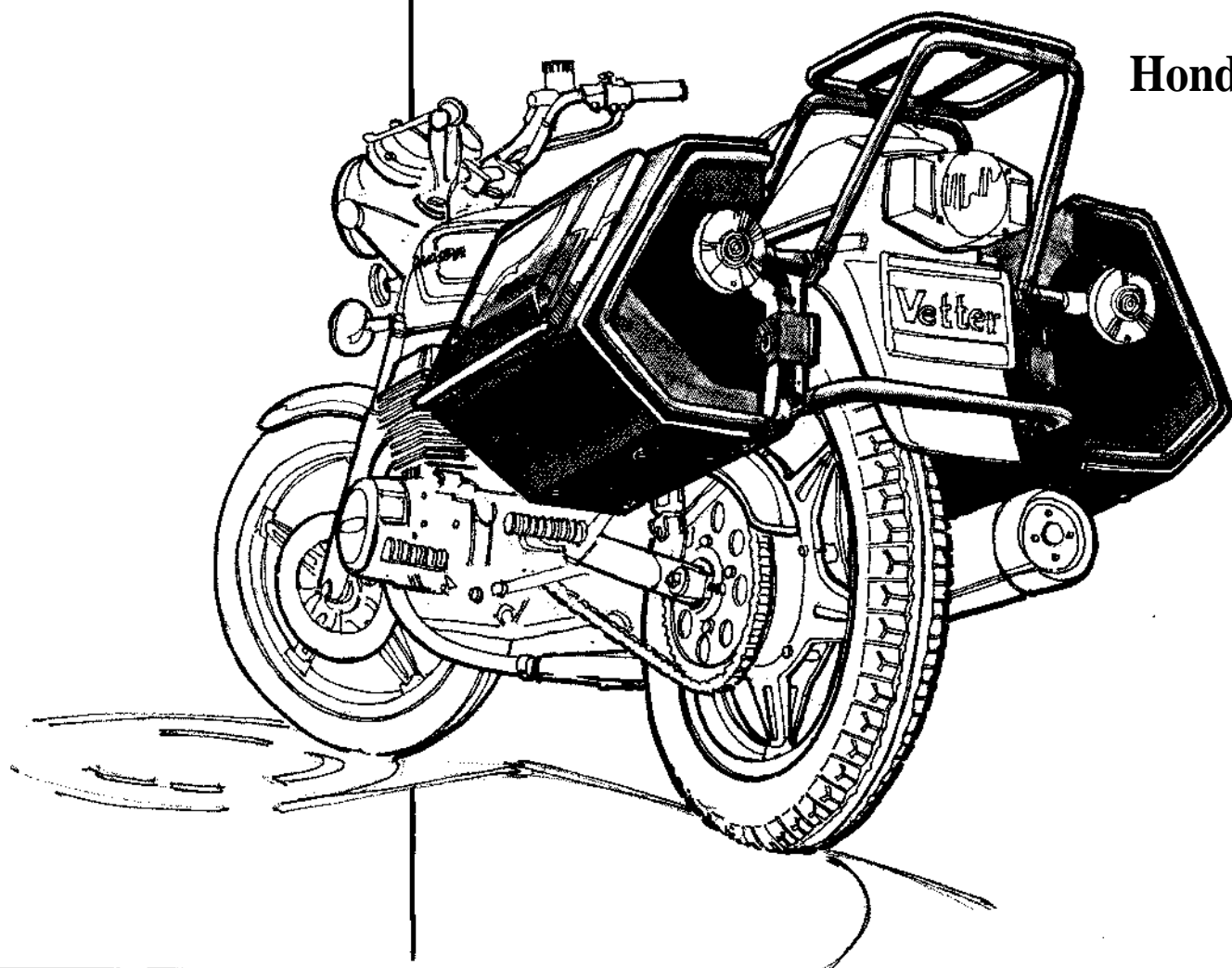

Vetter

Vetter Corporation 1150 Laurel Lane, San Luis Obispo, California 93401 805/541-2900

Table of Contents

INTRODUCTION	2
PREPARATION FOR HARDWARE MOUNTING ...	3-5
HARDWARE PARTS NOMENCLATURE	6
INSTALLING THE HARDWARE	7-10
SADDLE BAG PARTS NOMENCLATURE	11
SADDLE BAG DOOR MOUNTING	11-13
SADDLE BAG MOUNTING	13-14
CARRYING THE SADDLE BAGS	15
MAINTENANCE	16
CUSTOMER SERVICE	16
WARRANTY	16

SPECIAL NOTE: To comply with federal legislation, this manual must be given to the consumer. It contains their copy of the limited Warranty and can be useful for their future reference.

This manual contains important information regarding the proper installation, safe operation and maintenance of your Floating Mount Saddle Bags. While it may appear lengthy, we urge you to read it completely, understand all components of your Saddle Bags and Floating Mount Hardware and follow the recommendations to obtain the most trouble-free and enjoyable operation.

In this manual, statements preceded by the following words are of special significance:

WARNING — means that there is the possibility of injury to yourself and others.

CAUTION — means that there is the possibility of damage to the saddle bags and related components.

NOTE — indicates points of particular interest for more efficient and convenient installation and operation.

We recommend that you take particular notice of these items when reading this manual.

The intent of this manual is to insure that your Floating Mount Saddle Bags are properly installed — PLEASE USE IT!

First, we recommend that as you unpack your saddle bags, use the hardware parts nomenclature guide and saddle bag parts nomenclature guide (found in the table of contents) to study and recognize the various parts, so you will understand the detailed assembly steps that follow. Working straight through the manual will assure that nothing is overlooked or forgotten. If you wish to stop at any point during

the installation of your saddle bags, do so at the end of an assembly step.

CAUTION: Follow the assembly steps in their correct order. Completely finish one step before proceeding to the next assembly step.

This manual is broken into three major sections: Preparation for Hardware Mounting, Installation of Hardware and Saddle Bag Door Mounting & Saddle Bag Mounting. In the first section, Preparation for Hardware Mounting, you will prepare your motorcycle for the saddle bag hardware by disconnecting or removing some of your motorcycle's parts. Some of these original parts will be reused and others will not. The second section deals with actually installing the Floating Mount Hardware on your motorcycle. Use all of the indicated hardware in the order shown. In the third and final section you will be instructed on how to complete assembly of your saddle bags and mount them on your motorcycle.

As you are following the instructions, double check the following points, as they are critical:

1. Carefully check wiring color codes.
2. If you have safety bars, check carefully to determine if they are compatible with the saddle bag mounting system.
3. Check for clearance and tighten all bolts before operating your motorcycle with the newly installed saddle bags and hardware.
4. Periodically check and retighten all bolts and clamps after installation.

People have continually asked me "Why don't you build some good saddle bags?" Well, in the past, building Windjammers has been totally consuming. But now, with our new facility in San Luis Obispo, CA. we have the time and place to do new things.

For some time now, all of our talent and resources has been devoted to designing and engineering rear luggage that is as

good as our Windjammer. In fact, in many ways it's more advanced.

Considering what other saddle bags are like today, I think you will agree that our Floating Mount Luggage is the first to do it right.



Craig Vetter, Designer
San Luis Obispo, CA.

Introduction

Note from Craig Vetter

Preparation for Hardware Mounting

Honda 750F

1

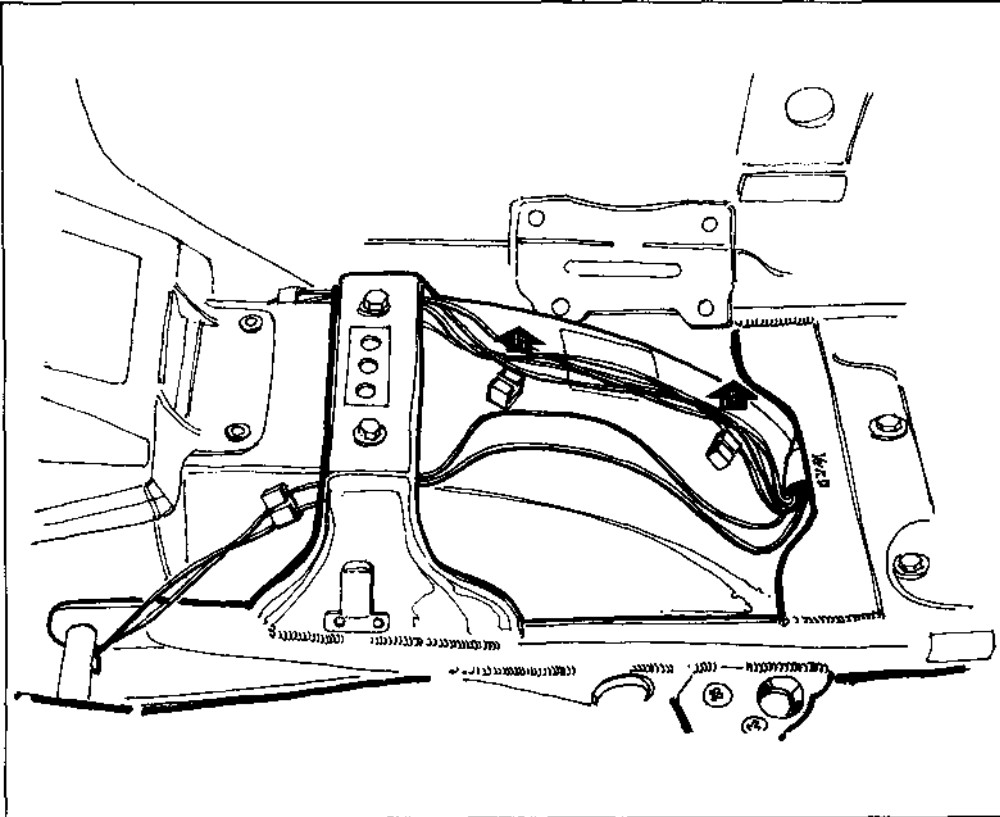

Objective

Installation of the Floating Mount Saddle Bag hardware may require the disassembly and/or removal of your motorcycle's turnsignals, grab bar mounts, passenger footrests and seat.

Open seat

Refer to your motorcycle's owner's manual.

Remove wiring from clips

Pull the wiring from the two clips located on top of the rear fender.

2

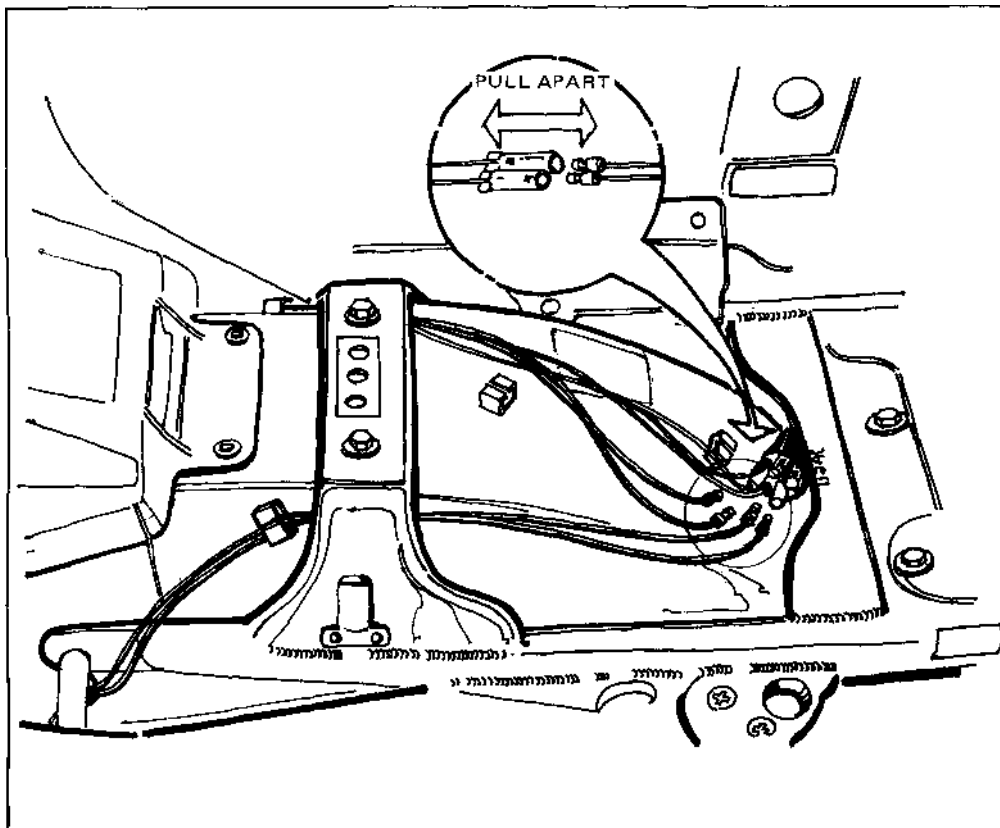

Disconnect turnsignal wiring

Pull the group of wire connections from under the frame member and slip the black cover off of the connections by pushing it down the wiring harness.

Trace the turnsignal wires from the turnsignal stalks and disconnect them at their bullet connectors. There are 4 black wires: one with a blue marker, one with an orange, and two with green markers.

3

Unroute turnsignal wires

Unroute the turnsignal wires from under the frame brace and through the wire loop located next to the turnsignal stalk mount on the grab bar.

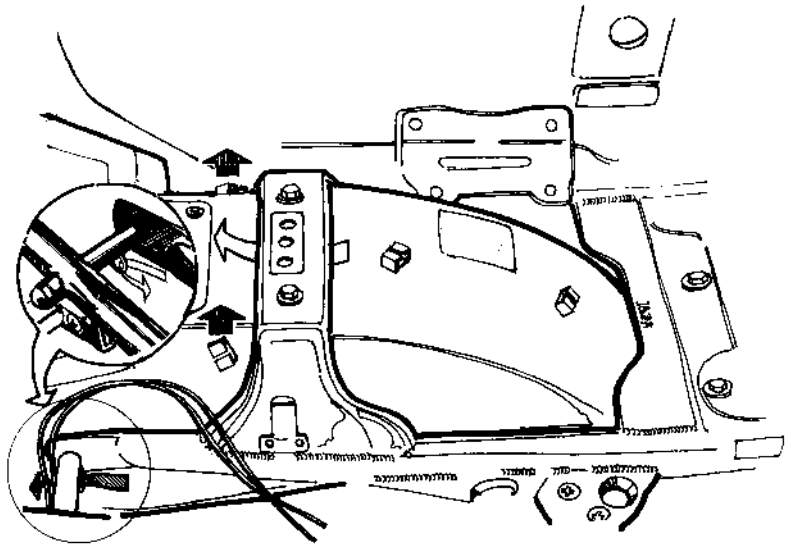

4

Remove turnsignal lamp bolts

Using two 10mm wrenches, remove the bolt and nut which secure the turnsignal lamp to its stalk. The bolt must be completely removed.

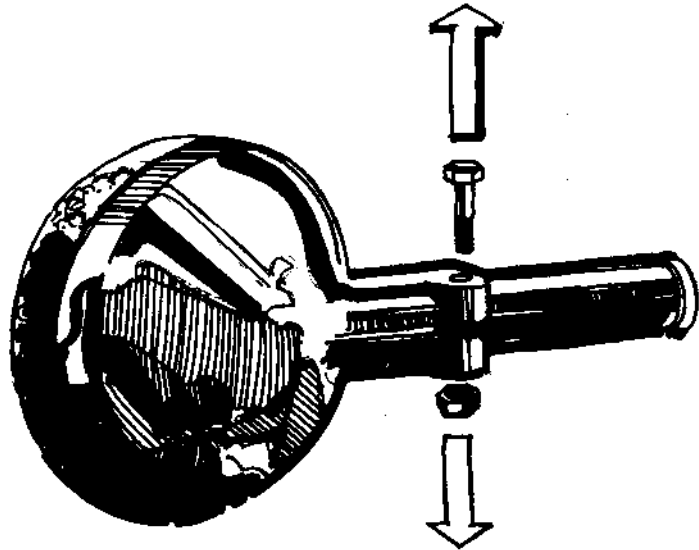

5

Remove turnsignal lamps from stalks

While spreading the surface of the split on the turnsignal lamp housing with a large screwdriver, etc. pull the lamp off of the stalk and completely away from the bike while threading its wire through the stalk.

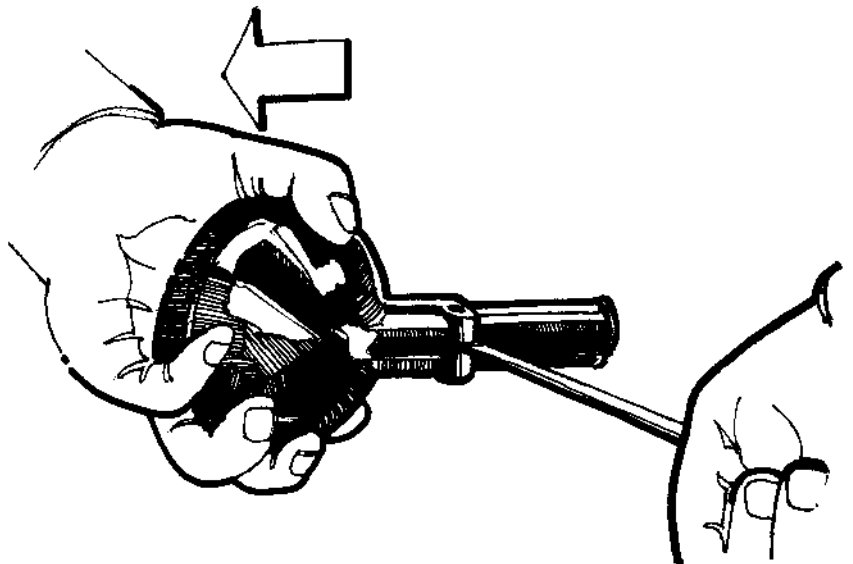

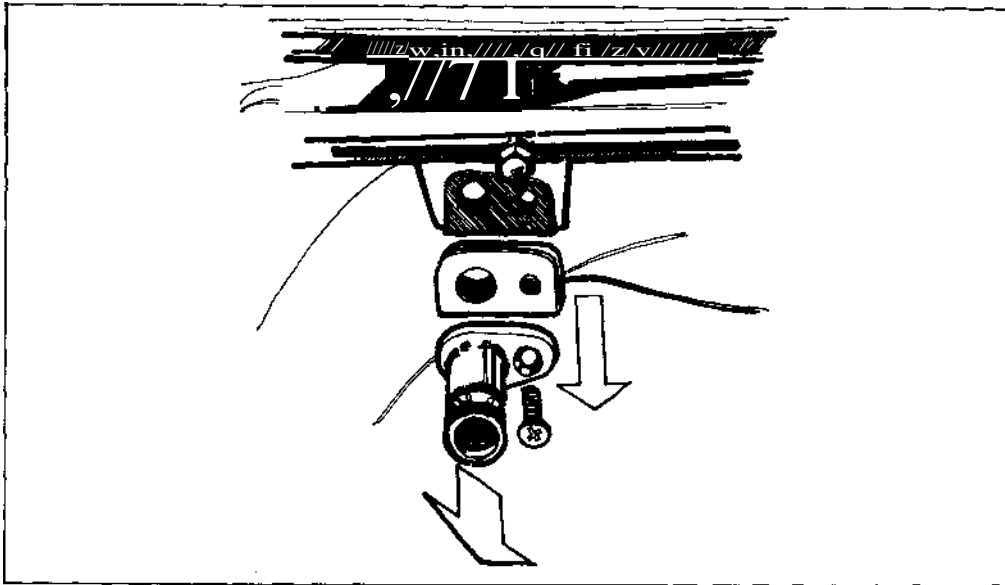

6

Remove turnsignal stalks and brackets

Remove the phillips head screw which secures the turnsignal stalk to the grab bar. Pull the stalk away from the bracket and pull the bracket down off of the mounting tab on the grab bar. Leave the rubber grommet in place.

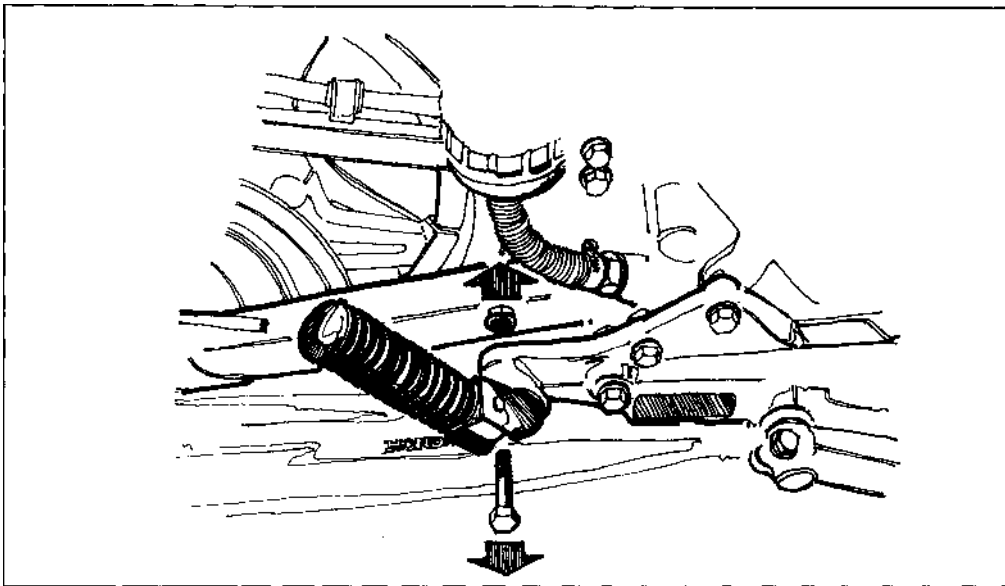

7

Remove passenger footrest

Using a 14mm socket, remove the passenger footrests. The left side needs no back-up wrench but the right side does — use a 14mm wrench.

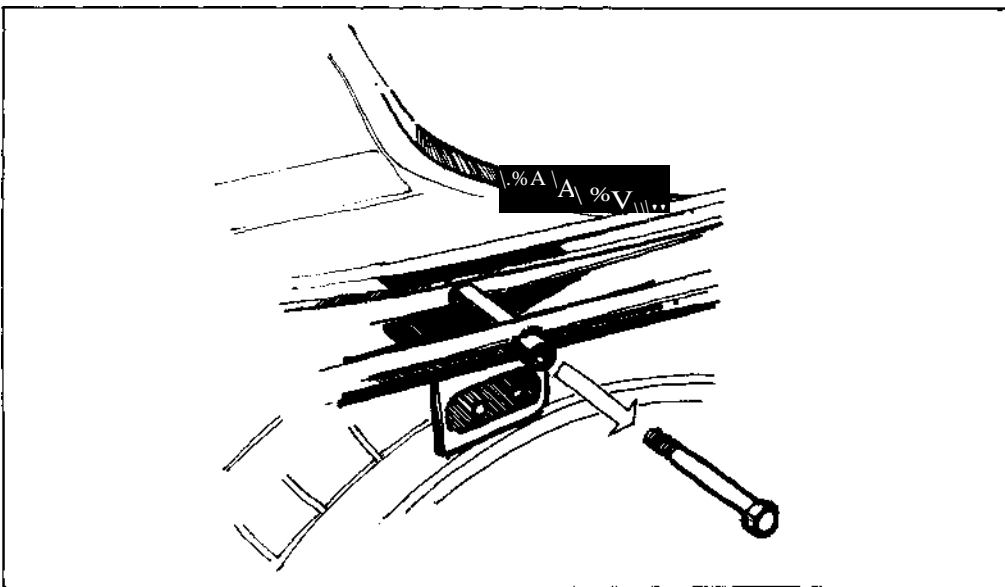

8

Remove grab bar mounting bolts

Remove the bolts which secure the grab bar at the rear mounts (one on each side) with a 12mm wrench.

Hardware Parts Nomenclature

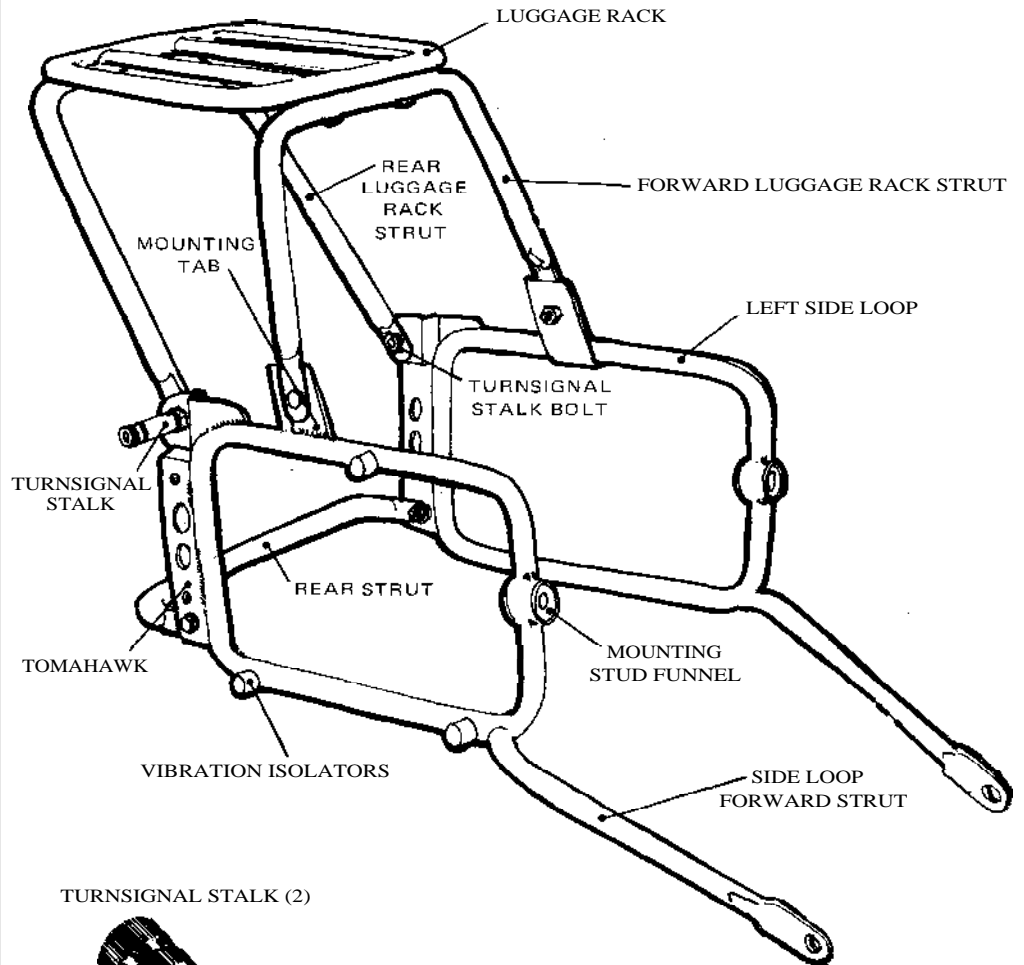

TURN SIGNAL STALK (2)

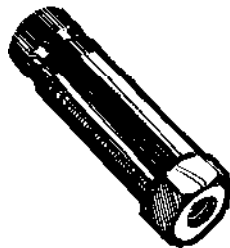

TURN SIGNAL STALK BOLT (2)

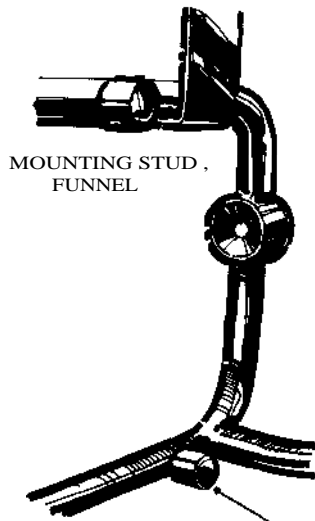

MOUNTING STUD FUNNEL

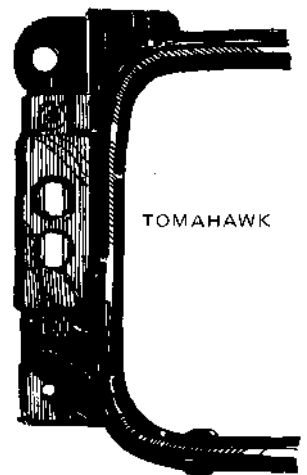

TOMAHAWK

VIBRATION ISOLATORS

Installation of the Hardware

Honda 750F

1

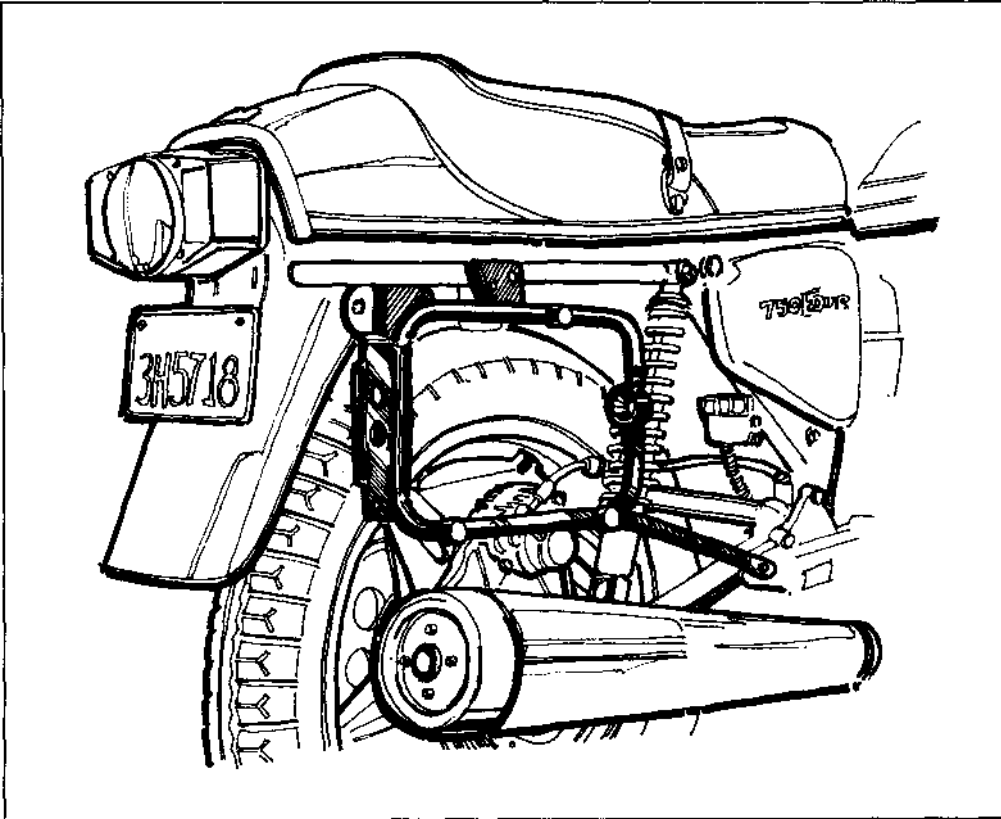

Objective

The Floating Mount Saddle Bags are designed to fit a large number of different motorcycles. Each model motorcycle has specially designed mounting hardware. When installed properly, the hardware will locate the saddle bags at the proper height and fore and aft location on your motorcycle. Use all of the hardware specified and periodically check for tightness after installation.

Position the side loop

Start with either side and position the side loop as shown.

2

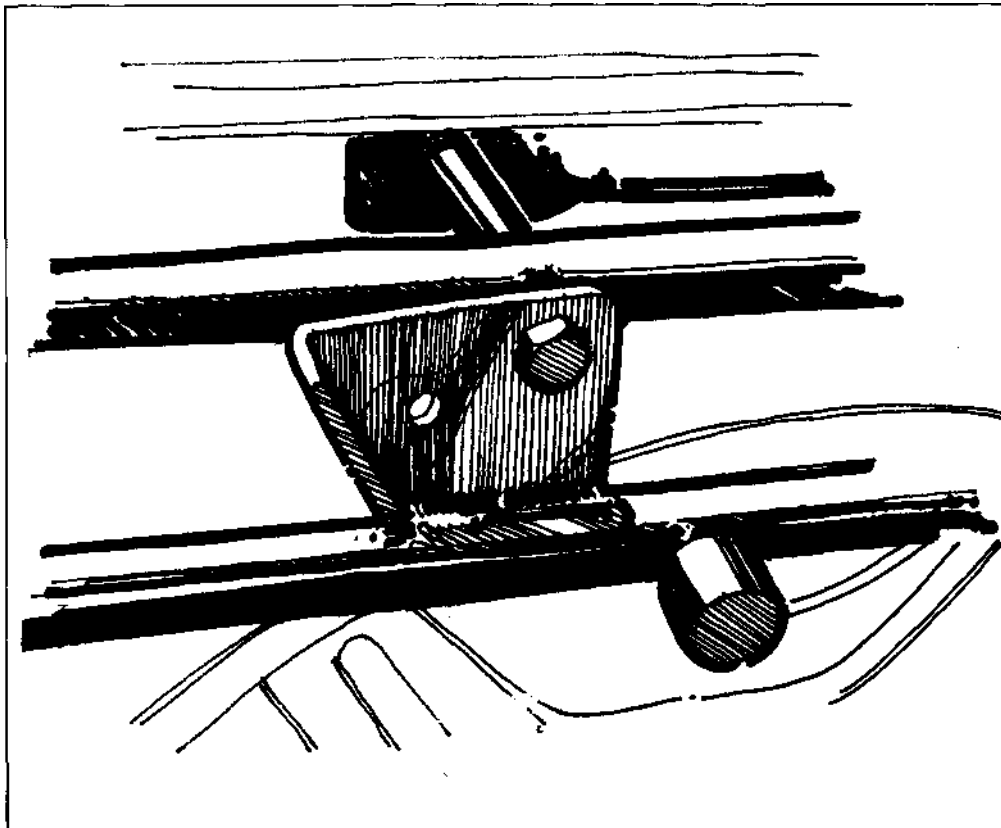

Mount the side loop at the grab bar mount

While holding the side loop in place, slide the supplied 8mm x 90mm bolt through the side loop mounting tab and into the grab bar mount.

NOTE: A metric scale is supplied on page 6 for your ease in identifying different fasteners.

3

Mount the side loop at the passenger footrest

Use the supplied 10mm x 50mm bolt and 10mm lock nut on the right and the supplied 10mm x 40mm bolt and 10mm lock nut on the left to secure side loop at the passenger footrest mount.

Assemble all parts in the order shown.

NOTE:

Inset drawing shows right hand side.

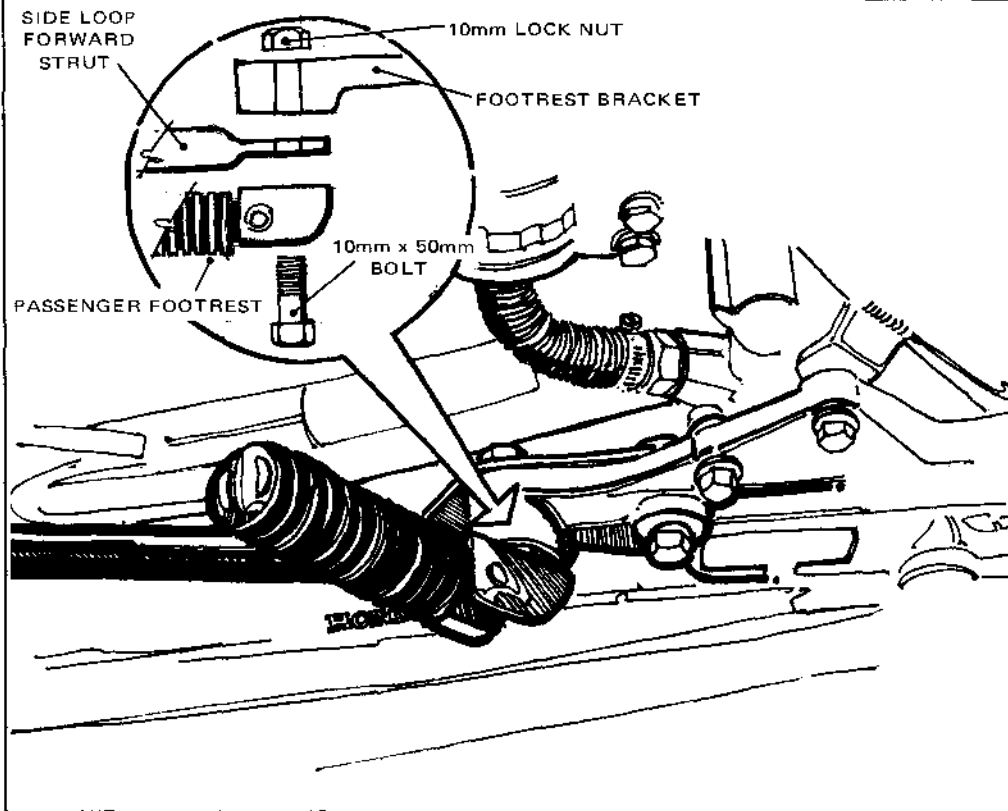

4

Mount the rear strut

Locate the rear strut and secure it to the side loop tomahawks at the position shown with 2-6mm x 20mm bolts, 4-6mm flat washers and 2-6mm lock nuts.

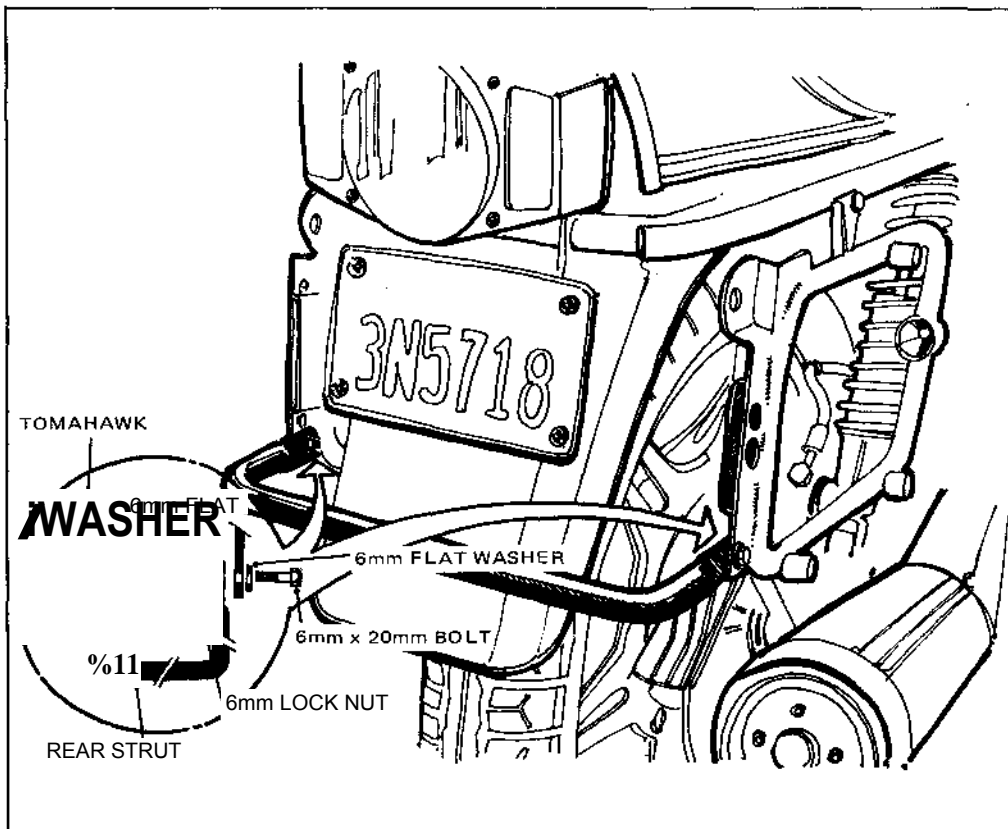

5

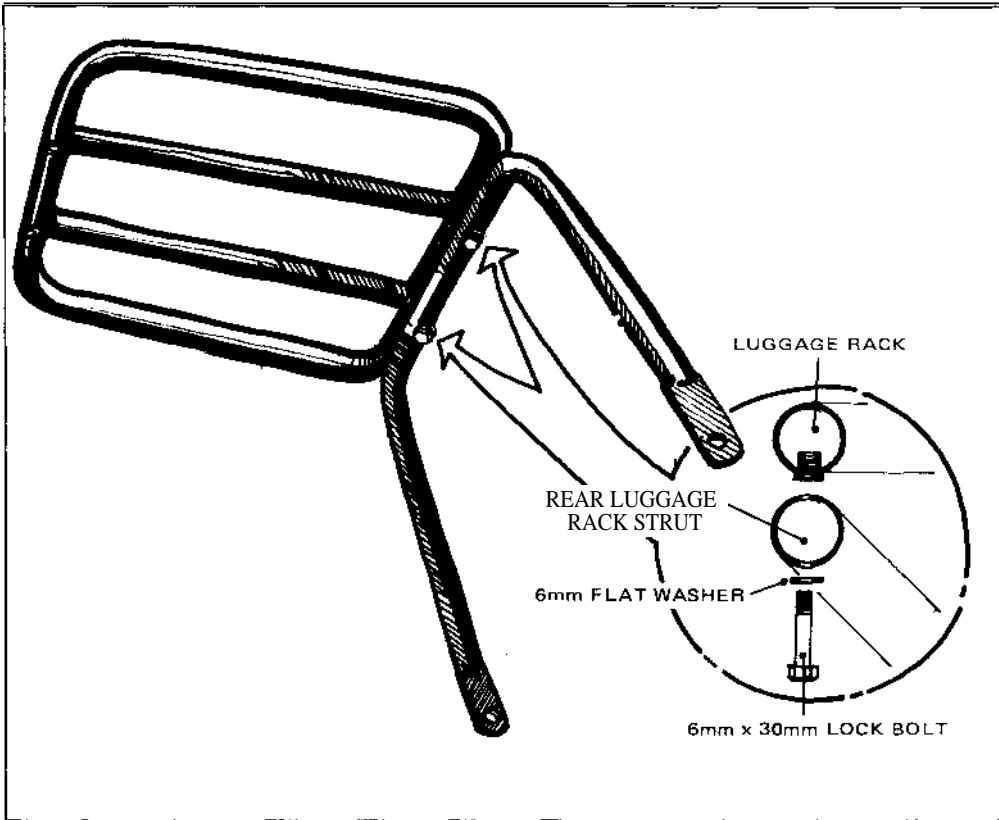

Mount luggage rack to forward luggage rack strut

Positioning the parts as shown, bolt them together with the supplied 2-6mm x 30mm lock bolts and 2-6mm flat washers.

NOTE: Installation of the Floating Mount Hardware on this particular model motorcycle does restrict access to areas underneath the seat. To obtain access, the forward luggage rack strut must be unbolted from the side loops. Therefore it is suggested that you carry your motorcycle's tool kit in one of the saddle bags.

6

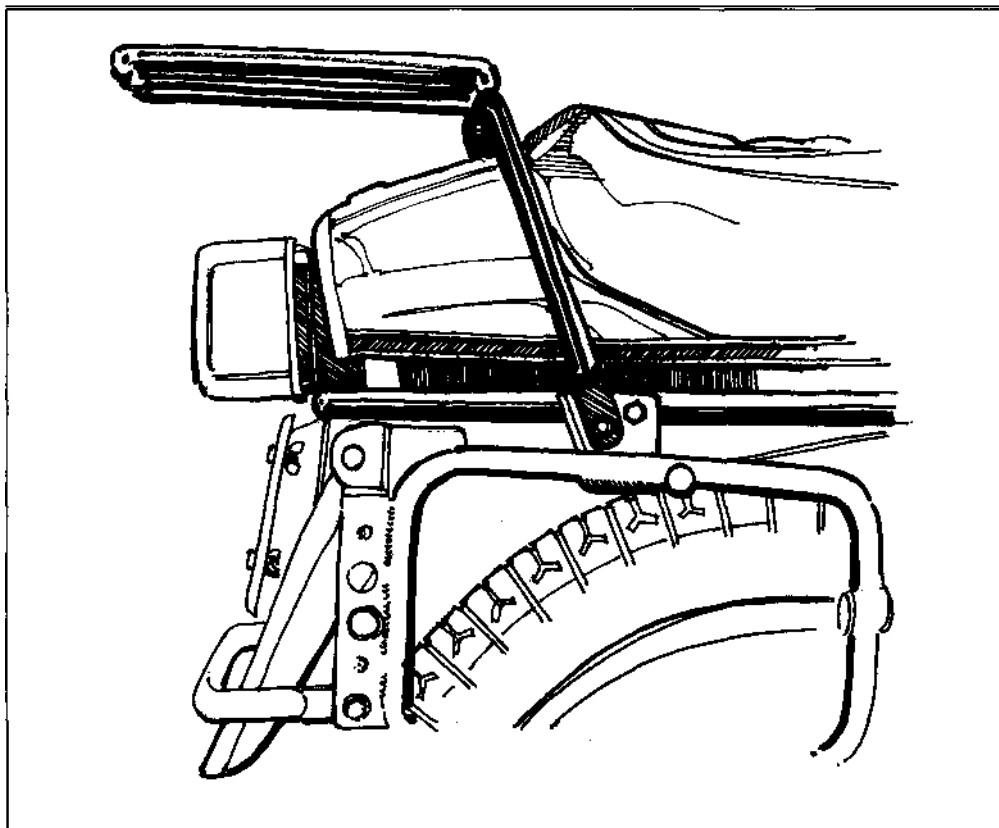

Mount the forward luggage rack strut to the side loops

Using the supplied 2-8mm x 16mm bolts and 2-8mm lock nuts, secure the forward luggage rack strut to the side loop.

7

Mount the rear luggage rack strut and turnsignal stalks to the tomahawks.

Mount the rear luggage rack strut to the tomahawks in the position shown (the holes in the upper section of the strut should line up with those in the luggage rack) with the two special turnsignal stalk bolts and the two supplied turnsignal stalks. Assemble the parts in the order shown.

Special wiring note: To achieve a good electrical ground, it is suggested that you scratch the surface of the rear luggage rack strut and tomahawk where the turnsignal stalk and bolt contact them.

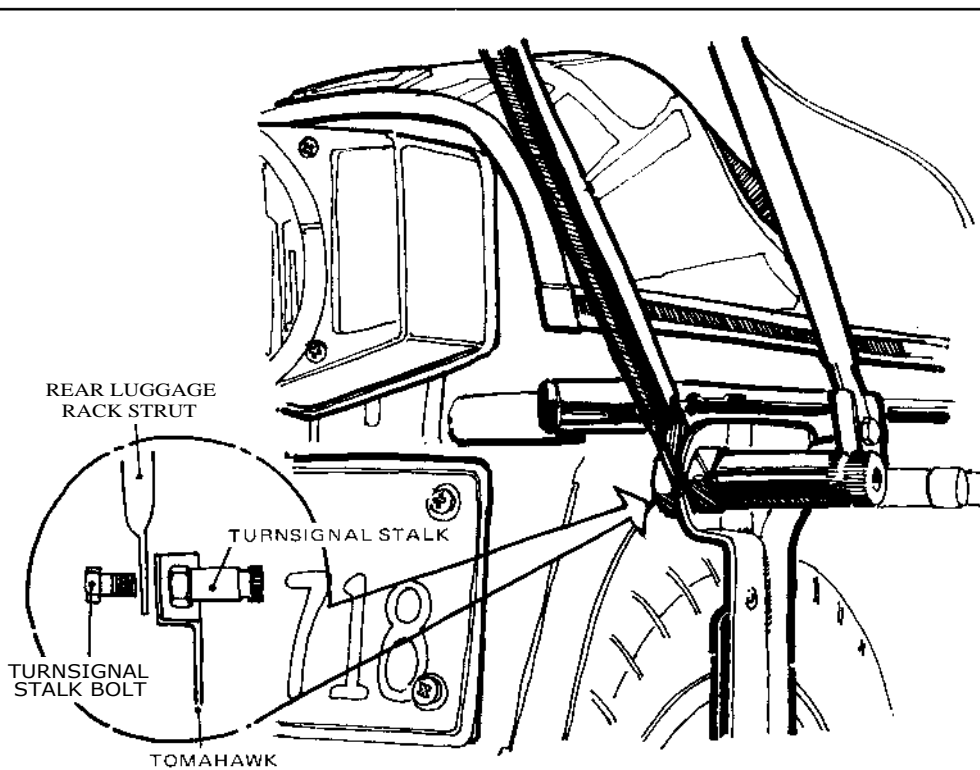

8

Mount luggage rack to luggage rack rear strut

With 2-6mm x 30mm lock bolts and 2-6mm flat washers, mount the luggage rack to the rear luggage rack strut.

Electrical hook-up
Run the wire of each turnsignal (L-orange, R-blue) through its stalk. Reverse the procedure in steps 5, 4, 3, 2 and 1 under Preparation for Hardware Mounting. Before connecting the wires together add the 7" wire extensions. Match colors and connect.

NOTE: Check turnsignals for correct operation. Refer to Troubleshooting, if not.

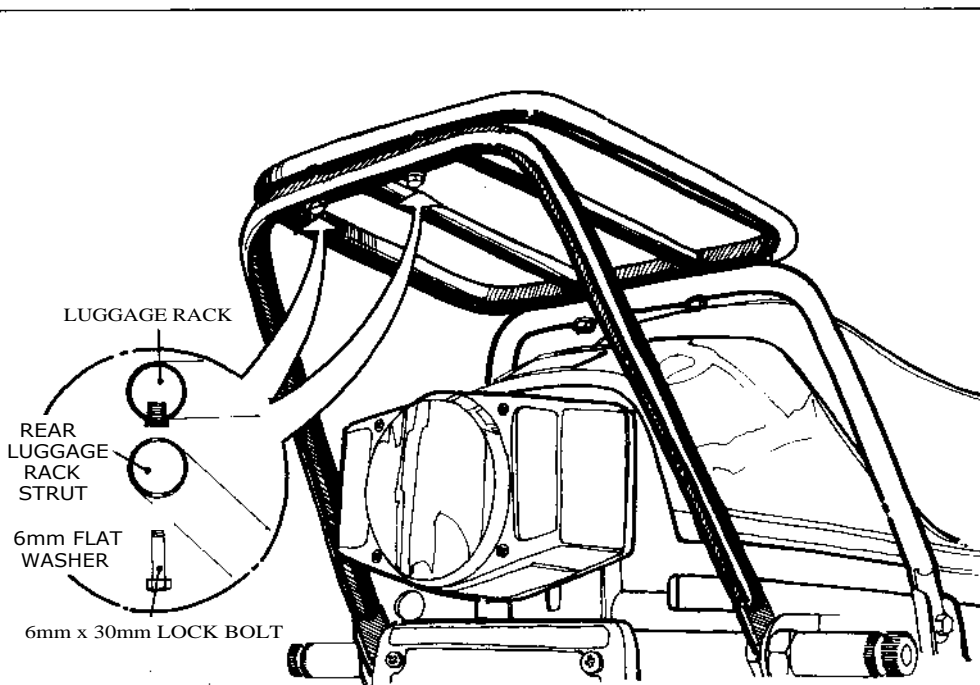

Saddle Bag Parts Nomenclature

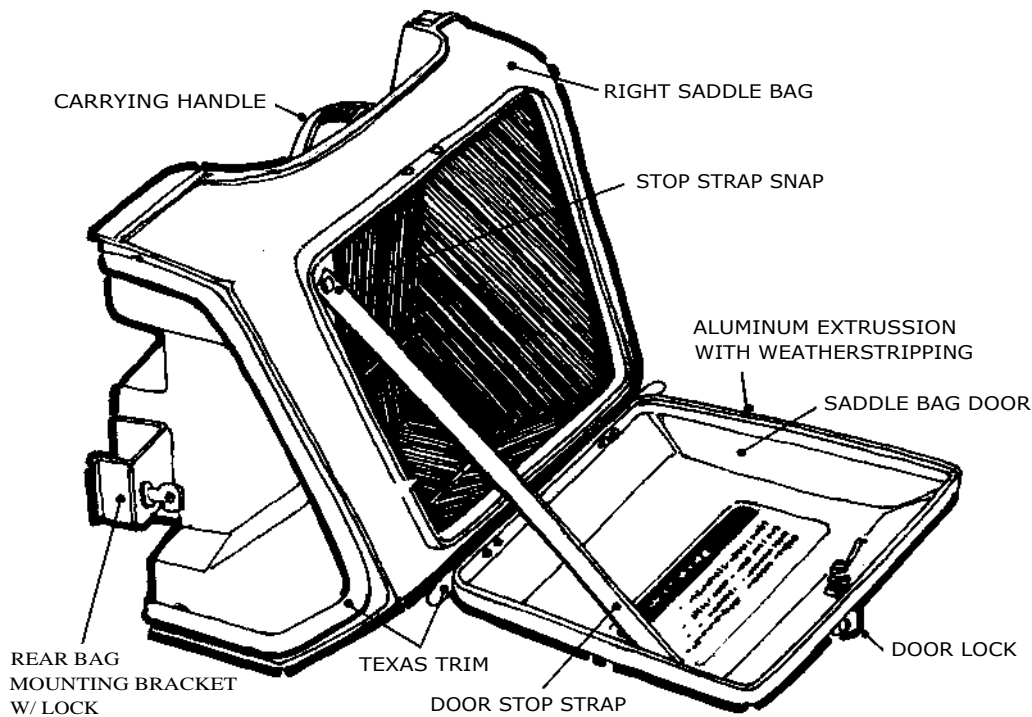

Saddle Bag Door Mounting

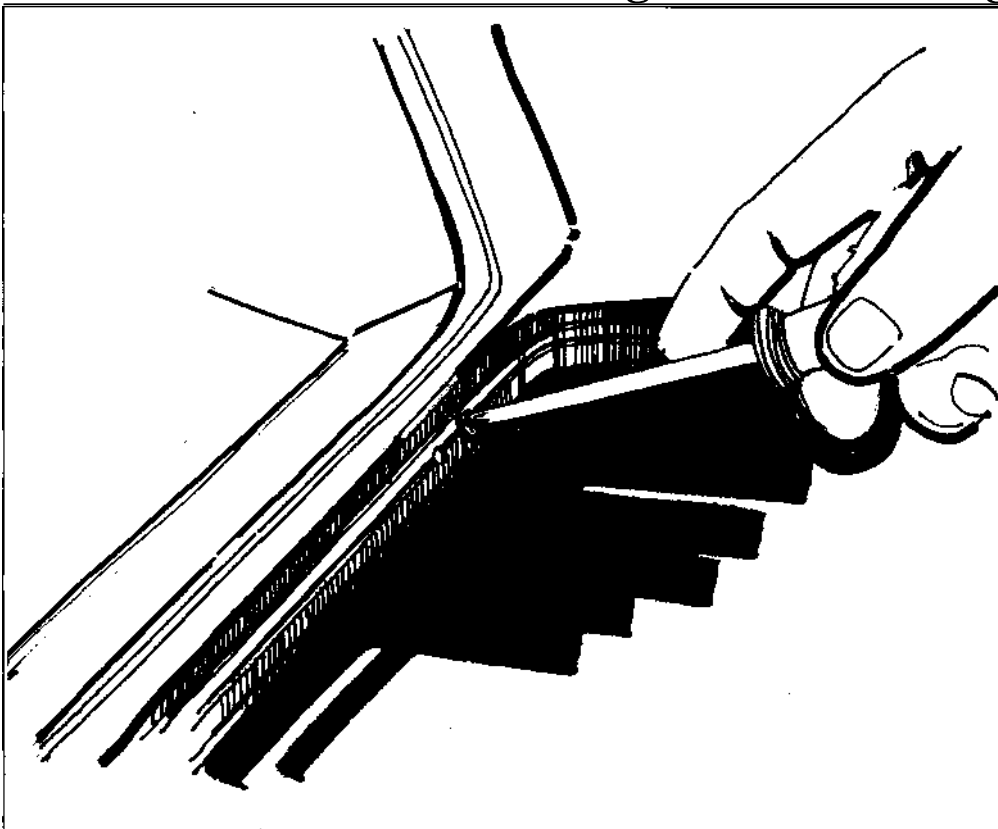

1

Objective

In order to supply saddle bags of various colors, the doors are packaged separately and require a simple mounting procedure before the bags are ready for use.

Separate left and right saddle bags, doors & Texas Trim.

Assemble one bag at a time.

Position door on hinges

Using 2-4mm x 12mm screws, insert one screw at each hinge point from the inside of the door. Position the door on the hinges.

2

Positioning the Texas Trim

Next position the Texas Trim over the screws (be careful not to apply too much pressure on the screws or they will be forced into the bag).

Thread nuts onto phillips head screws

Now thread the 4mm lock nuts onto the screws and tighten.

Unlock the door and insert the two remaining screws through the door, hinge and Texas Trim and thread on their nuts & tighten.

Repeat the above three (3) steps for the remaining bag.

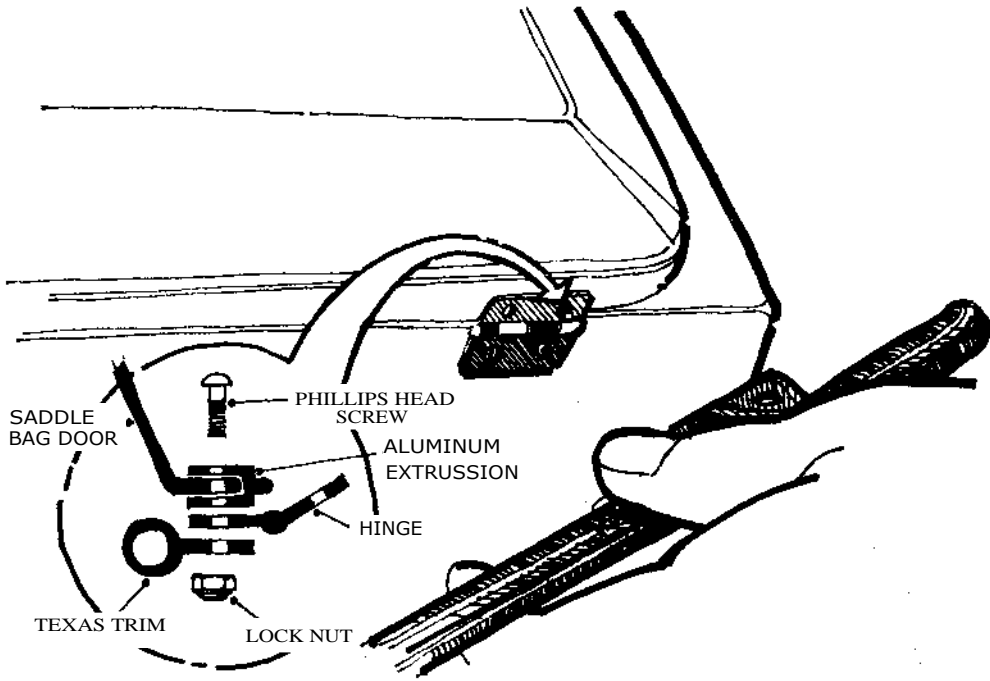

3

Mounting Saddle Bag door lock

To mount the saddle bag door lock (packaged with the bag) simply insert the lock through the door, slide on the large star washer and thread on the nut. Do not overtighten.

Mount the locking cam straight up when the key lock is in the locked position (when the key can be removed). Assemble the parts as shown.

Mounting Texas Trim at rear of bag

Mount the Texas Trim to each bag at 3 places with 3 black spacers, 3 nylon washers & 3 phillips head screws.

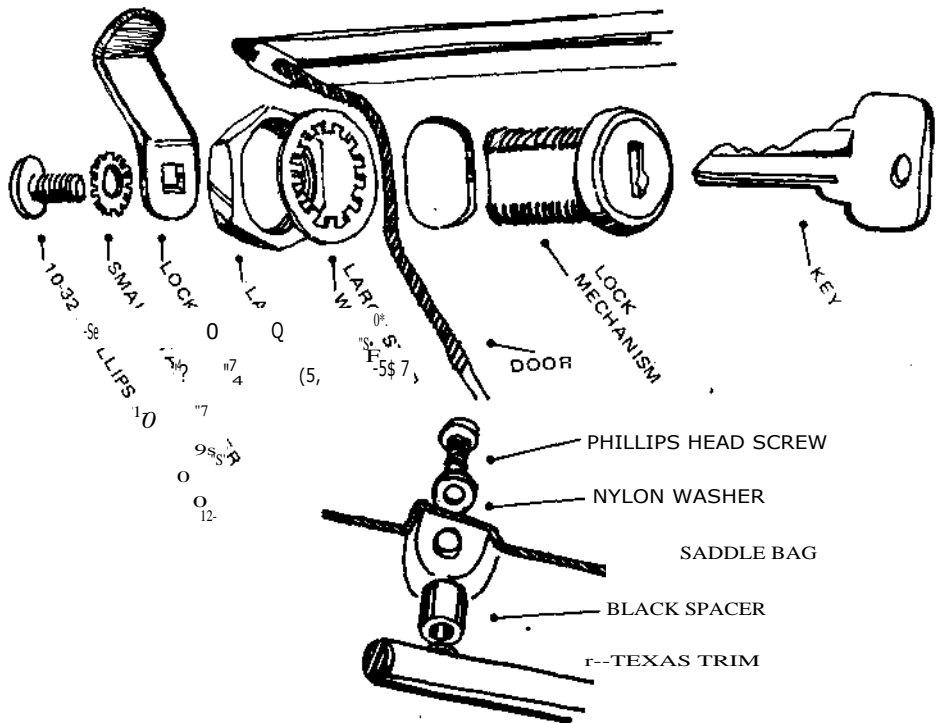

4

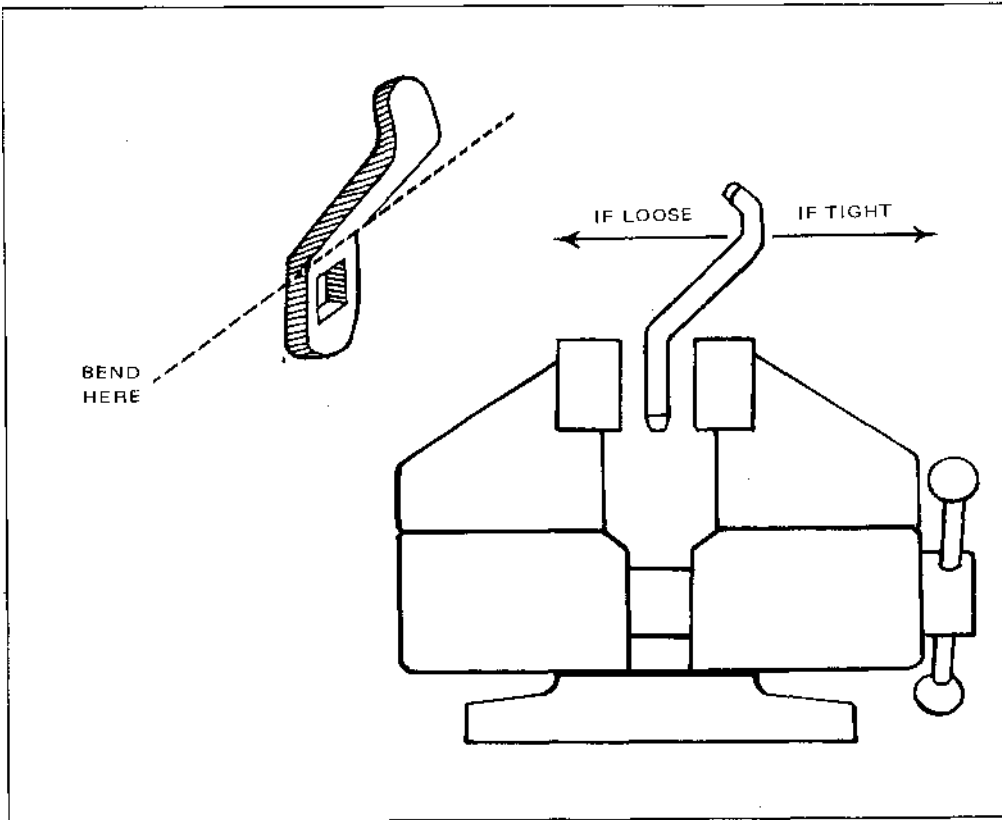

Connecting snap of door stop strap

Snap the door stop strap into position as shown.

Locking cam adjustment

When locking the door, there should be a moderate amount of resistance to key movement. Too much or too little resistance indicates a need for locking cam adjustment. This is done by removing the cam, clamping it in a vise, and tapping it firmly with a hammer in the appropriate direction to increase or decrease resistance. Generally, a 10-15 degree bend is sufficient. Extended use may also necessitate an adjustment, in which case, the above procedure also applies.

Saddle Bag Mounting

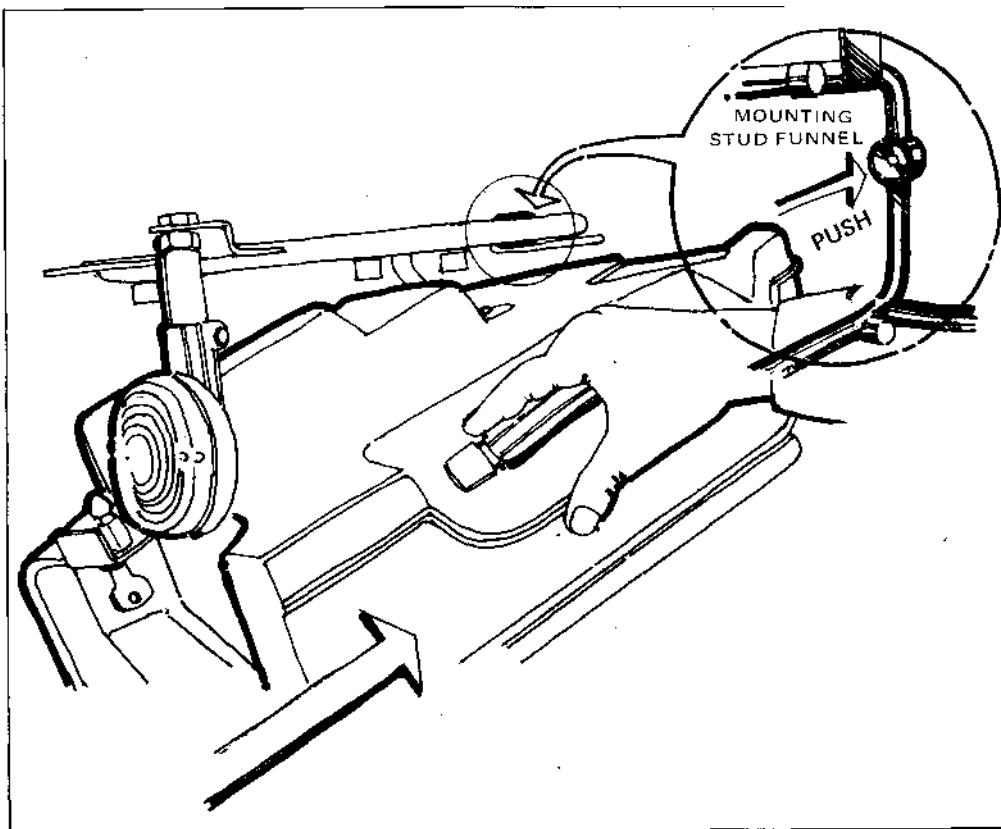

1

Objective

Once all of the Floating Mount Saddle Bag Hardware is attached to the motorcycle and the doors and trim are mounted on the saddle bags, the saddle bags are ready to be mounted on the motorcycle.

Mounting the saddle bag at its forward mount

Starting at the forward mount insert the mounting stud into the stud funnel while holding the bag out at an angle as shown.

2

Mounting the saddle bag at its rear mount

While holding the forward mount in position, push the rear mount of the bag to the side loop tomahawk. Insert the conehead into its spring loaded receptical (an audible "click" will be heard when the conehead is fully engaged.)

The bag is now mounted and ready for use.

CAUTION: To avoid saddle bag damage from muffler heat, a minimum clearance of 19mm (3/4") is needed. To obtain desirable tail pipe clearance it may be necessary to loosen saddle bag hardware: apply upward pressure then tighten into place. Follow by loosening muffler; apply downward pressure to muffler, and retighten.

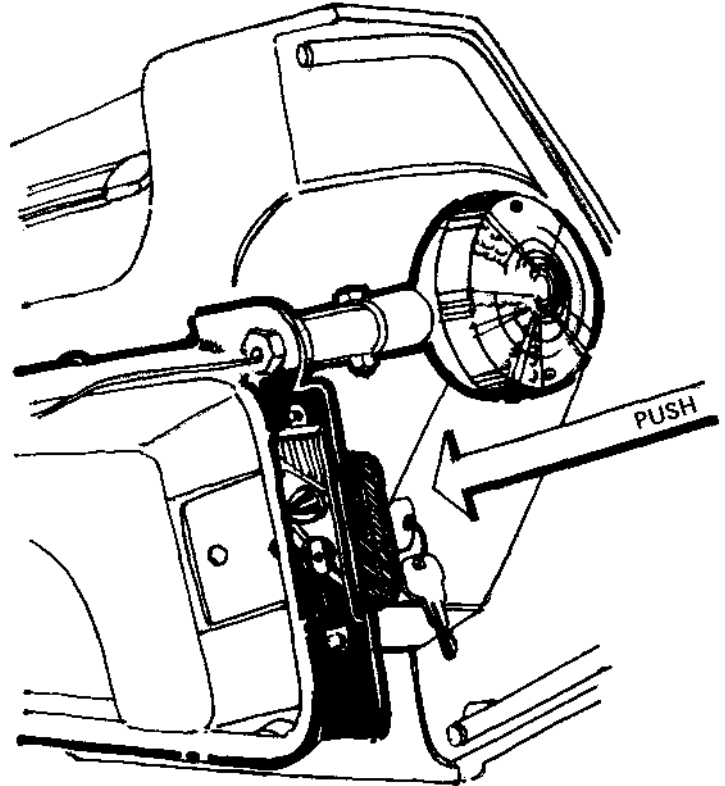

3

Saddle bag removal

To remove the bag, simply turn the locking key to its release position, and pull the rear of the bag out and back to disengage the forward mount.

NOTE: If the conehead and/or latch mechanism become difficult to operate, a thin layer of oil on the parts should correct the problem.

NOTE: Use only powdered graphite on the locks themselves for lubricant.

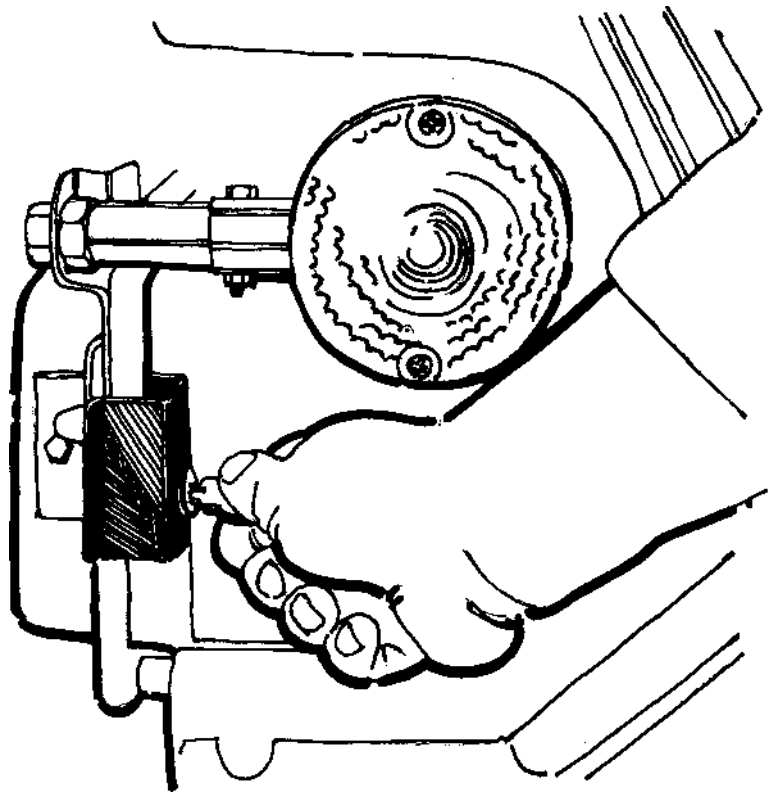

4

Carrying the Floating Mount Saddle Bags by hand

When carrying the saddle bags by hand, they are designed to be carried with the doors facing you.

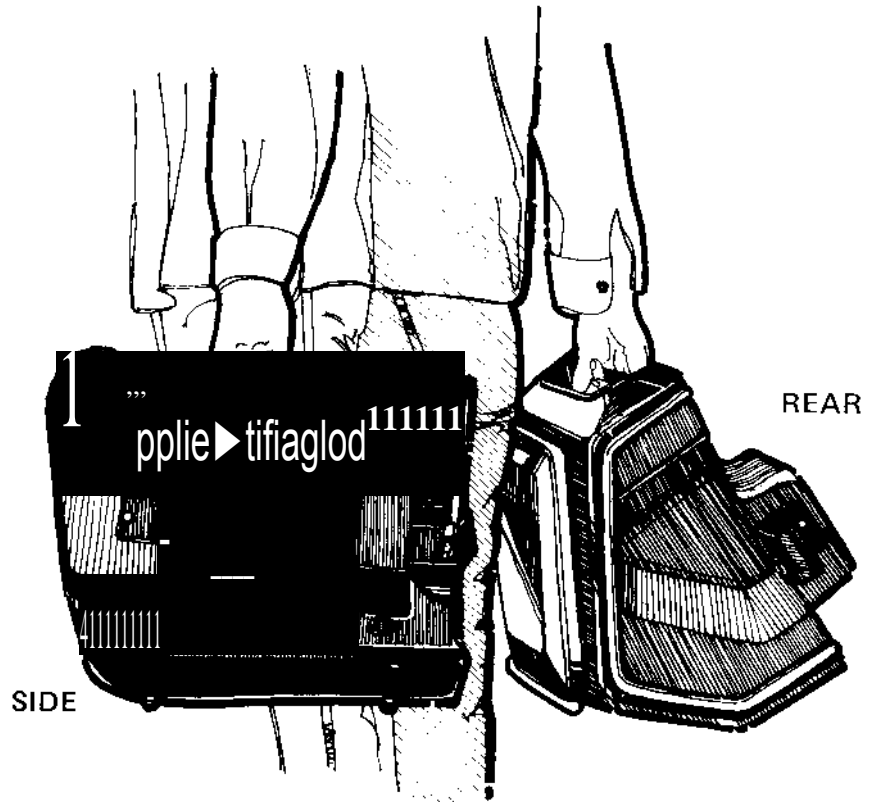

SPECIAL NOTE: Vetter Corporation reserves the right to make changes in design and specifications, and/or to make additions to or improvements in its products without imposing any obligations upon itself to add or install them on products previously manufactured or sold.

A WARNING

**READ CAREFULLY
BEFORE LOADING**

THE SADDLEBAGS, TAIL TRUNK AND LUGGAGE RACK ARE FOR LIGHT WEIGHT ITEMS. EXCESSIVE WEIGHT AND IMPROPER LOADING MAY AFFECT MOTORCYCLE STABILITY, DECREASE SAFE OPERATING SPEED, AND CAUSE MOUNTING HARDWARE OR SADDLEBAG FAILURE.

A DO NOT EXCEED A COMBINED MAXIMUM LOAD OF 27 KGS. (60 LBS.) IN THE SADDLEBAGS AND TAIL TRUNK OR ON THE LUGGAGE RACK. DISTRIBUTE THE LOAD EQUALLY ON BOTH SIDES OF THE MOTORCYCLE. DO NOT EXCEED A MAXIMUM LOAD OF 9 KGS. (20LBS.) FOR EACH SADDLEBAG.

FACTORS BEYOND OUR CONTROL SUCH AS OPERATOR'S WEIGHT, PASSENGER'S WEIGHT, WEIGHT OF OTHER ACCESSORIES, ETC. MAY FURTHER REDUCE THE SAFE AMOUNT OF WEIGHT CARRIED IN OUR SADDLEBAGS AND TAIL TRUNK OR ON THE LUGGAGE RACK.

DO NOT EXCEED YOUR MOTORCYCLE'S VEHICLE CAPACITY LOAD LIMIT AS SHOWN ON ITS TIRE INFORMATION LABEL AND AGAIN IN YOUR MOTORCYCLE OWNER'S MANUAL.

A REFER TO THE INSTALLATION INSTRUCTIONS FOR ADDITIONAL INFORMATION. IF YOU HAVE ANY QUESTIONS CONTACT YOUR DEALER, OR:

CUSTOMER SERVICE DEPT.
VETTER CORPORATION
1150 LAUREL LANE
SAN LUIS OBISPO, CA 93401
(805) 541-2900

CAUTION:

Any non-stock exhaust system mounted on a motorcycle equipped with Vetter saddle bags must provide a minimum clearance of 25.4mm(1 inch) between any part of the tail pipe and the bottom of the saddle bags. In addition, exhaust gases must not be directed toward the saddle bag.

Troubleshooting and Maintenance

ELECTRICAL

If your problem is electrical, check your color code to insure the proper wires have been connected. A loose bullet connector connection can be improved by unplugging the connector and making the female receptacle smaller by use of pliers and then reinstalling the bullet connector. If your turnsignals do not function properly, your ground connection is probably not making good contact, or your battery is weak and needs to be serviced.

If there are any problems that cannot be solved by you or your dealer, contact the Customer Service Department of Vetter Corporation, 1150 Laurel Lane, San Luis Obispo, CA 93401 (805) 541-2900.

MOUNTING

The best answer to almost any problem is to reread your instructions carefully. Sometimes it is helpful for someone else to look the problem over, especially someone who has not been working on the installation with you, such as your dealer.

MAINTENANCE

The Floating Mount Saddle Bags require little maintenance, but we recommend that you make periodic checks. The mounting bolts and mounting clamps should be checked for tightness and adjustments made as necessary.

Cleaning and waxing the Saddle Bags: When washing your saddle bags, use a mild detergent and warm water. Washing should be done with a soft cloth or sponge. Avoid spraying water under pressure directly at the joint between the door and the body of the saddle bag as some water may enter the bag itself. Waxing the saddle bags is easy; furniture polish works as well as anything we have found. Spray the polish on a rag rather than on the bag itself, however, as if it is sprayed on the bag the wax becomes very difficult to remove from the bag's textured surface.

CAUTION: Do not use cleansers which contain methyl or ethyl alcohol.

CAUTION: Hydraulic fluid will damage your saddle bags. Never allow it to come in contact with your saddle bags.

With normal use the bodies of your saddle bags may become scratched or marred. Small cosmetic touch-ups can be accomplished by treating the area with a hot air gun (a hair dryer is not hot enough) or a propane torch. Using either the torch or the hot air gun, pass back and forth over the marred area in a sweeping motion at a safe distance from the bag surface. The correct amount will smooth and restore shine to the damaged area. If the area in concern is located near the door or a painted part, that part should be removed before any treatment is performed.

PAINTING INSTRUCTIONS

If you wish to repaint your saddle bag doors, we recommend that the following instructions be used:

1. Remove the Floating Mount logo and stripe decals.
2. Sand thoroughly with 320 grit wet sandpaper.
3. Resand with 400 grit wet sandpaper.
4. Dry thoroughly.
5. Spray with Dupont 100S Multi-Purpose Primer.
6. Spray Dupont Weight Lifter Acrylic Enamel with 7925 or 7935 Hardener.
7. Install new vinyl decals.

SADDLE BAG STRIPING

When removing striping from the saddle bag doors, the suggested method is to use 3M Woodgrain and striping Remover, part number 08907, followed by 3M Adhesive Remover, part number 08908. Please follow the directions on the spray cans. These products can be obtained at most paint and automotive stores that carry 3M products.

When handling saddle bag striping, do not crease or bend it. Always handle striping from the edges, never from the ends. Do not pull the backing paper off the striping with expectations of reapplying. Backing paper will NOT restick.

If you have any questions on storing, handling, removing or applying of saddle bag striping that your dealer cannot answer, contact our Customer Service Department.

REPLACEMENT PARTS

We recommend that you always use Genuine Vetter Replacement Parts. Contact your local Vetter dealer to purchase or order replacement parts.

CUSTOMER SERVICE

Any problems concerning installation of the Saddle Bags should be referred to your dealer or the Customer Service Department, Vetter Corporation, 1150 Laurel Lane, San Luis Obispo, CA 93401. We are here to serve you: (805) 541-2900. In order to provide the maximum amount of service to you and the dealer, it is necessary that you fill out the Owner's Registration Card and promptly return it to Vetter Corporation. We also suggest you record your saddle bags Serial number here:

so you'll have it should you ever need to contact us: (It is located inside the left hand saddle bag.)

Also record your key number here—so that you can order replacement locks if necessary.

Limited Warranty—Vetter Corporation Products

This warranty applies to products manufactured or distributed by Vetter Corporation, 1150 Laurel Lane, San Luis Obispo, CA 93401, and sold by Vetter Corporation or its authorized dealers within the United States, Puerto Rico, and the Virgin Islands. It is given to the first retail purchaser only and is not transferable to subsequent owners.

Warranty Obligation: Vetter Corporation warrants that it, or one of its authorized dealers, will repair or, at its option, replace any part proven to be defective in factory material or workmanship within six (6) months (unlimited mileage) of the date of purchase. Parts repaired or replaced under this warranty are warranted only during the balance of the original warranty period. **THIS WARRANTY DOES NOT INCLUDE ANY LABOR CHARGES FOR TROUBLESHOOTING, REMOVAL OR INSTALLATION.**

Exclusions from Coverage: 1. Any repairs or replacements or parts necessitated by misuse, negligence, fire, accident, damage caused by exposure to gasoline, brake fluid, harmful solvents and cleaners, paints, or repair material, use of unauthorized accessories, faulty installation, installation upon motorcycles or vehicles not listed in Vetter Corporation's retail and dealer catalog sheets, or improper or unreasonable maintenance are not covered. 2. This warranty does not cover "Totes" rainboots.

DISCLAIMER OF CONSEQUENTIAL DAMAGES AND LIMITATIONS OF IMPLIED WARRANTIES: TO THE EXTENT THE LAW PERMITS, VETTER CORPORATION SHALL NOT BE LIABLE UNDER ANY CIRCUMSTANCES FOR LOSS OF USE OF THE PRODUCT, CONSEQUENTIAL OR INCIDENTAL DAMAGES. ANY IMPLIED WARRANTY ARISING

UNDER LAW, INCLUDING THOSE OF MERCHANTABILITY AND FITNESS FOR A PARTICULAR PURPOSE, IS LIMITED TO THE DURATION OF THIS LIMITED WARRANTY.

IMPORTANT: Some states do not allow limitations on how long an implied warranty lasts and/or limitations or exclusions or consequential or incidental damages, so the above limitations may not apply to you.

To Obtain Warranty Service: Information you must provide when filing claim: 1. Name, mailing address and telephone number. 2. Selling dealer's name and address. 3. Serial number of product. 4. Model and year of motorcycle. 5. Date product was purchased. 6. Date and mileage at failure. 7. Description of problem.

Steps to take: 1. Contact or take your product to an authorized Vetter dealer (preferably your selling dealer) at your expense. 2. If you are unable to obtain warranty service, or should your warranty claim be denied for reasons that you consider unjustifiable, contact the owner of your selling dealer. Normally, this should resolve your problem. However, if you require further assistance, write or call the Customer Service Department of Vetter Corporation, 1150 Laurel Lane, San Luis Obispo, CA 93401, (805) 541-2900. At this point, you must be prepared to return the part in question to Vetter Corporation with all freight charges prepaid. The charges will be reimbursed to you if they total over \$5.00 (five dollars) and the warranty claim is honored. This warranty gives you specific legal rights and you may also have other rights which vary from state to state.

June 23, 1978

Vetter Corporation

Floating Mount Saddle Bags

Owner's Manual and Mounting Instructions

Supplement

1979
Honda 750F

NOTE: The 1979 Honda CB750F factory-supplied exhaust is not compatible with the Floating Mount Saddle Bag system and must be replaced with a suitable substitute. Your dealer can probably suggest an exhaust system which is compatible.

6

Remove turn signals

Disconnect the turn signal wires. Remove the Phillips head screw securing the stalk to the tab. Thread the wiring through the tail section and remove the turn signal assembly.

page 5

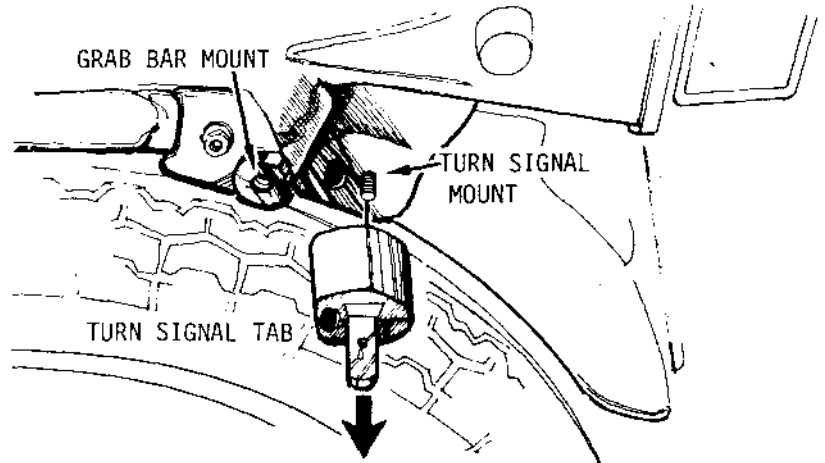

2

Mount side loop at grab bar mount

While holding the side loop in place, slide the stock bolt through the side loop mounting bracket and into the grab bar mount.

page 7

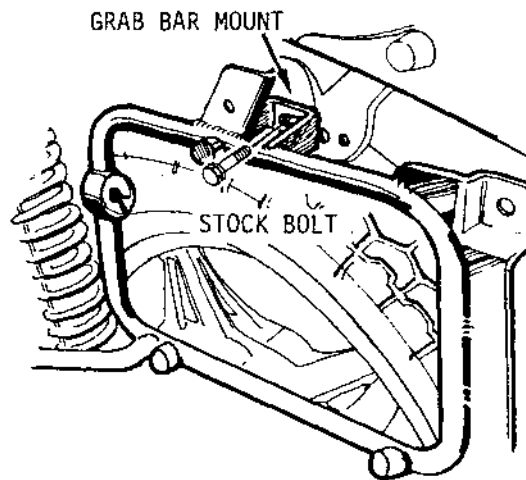

7

Mount luggage rack strut

Position the rear luggage strut, insert the turn signal mounting tab through the strut, tomahawk, flat washer and into the 12mm lock nut.

Attach the turn signal to the mounting tab with the original Phillips head screw. Reroute the wires and connect them at their designated bullet connectors.

page 10

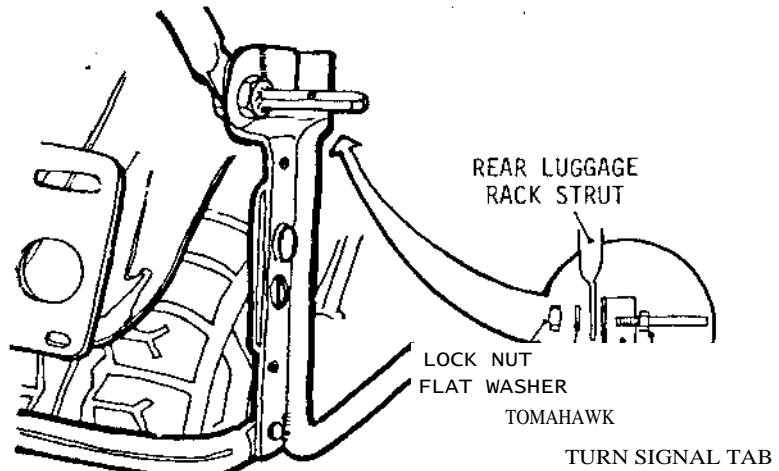

1979 HONDA CB750F

SADDLE BAG HARDWARE KIT

10 006 0123

Packina List

Use this hardware only on motorcycle(s) listed. This list current at time of printing.

Parts#	DESCRIPTION	
14 012 0103	Mounting Instructions	
15 003 0103	Hardware Bag	1
15 008 0129	Turn Signal Tab	2
17 024 0041	6x20mm Bolt	2
17 024 0062	6x30mm Bolt	4
17 024 0044	8x20mm Bolt	2
17 024 0063	10x55mm Bolt	2
17 026 0008	6mm Lock Nut	2
17 026 0009	8mm Lock Nut	2
17 026 0015	12mm Lock Nu	2
17 027 0005	6mm Flat Washer	8
17 027 0006	8mm Flat Washer	4
21 004 0008	Red Reflector	2
17 027 0007	10mm Flat Washer	2
17 5 0017	12mm Flat Washer	2
15 O 0203	Luggage Rack	1
15'009 0033	Rear Cross Strut	1
15 012 0010	Rear Luggage Rack Support	1
15 012 0030	Front Luggage Rack Support	1
15112 0098	Left Side Loop	1
151L2 0099	Right Side Loop	1
14 012 0121	1979 Honda CB750F Supplement	1